



Attendant®

TOUCHSCREEN VITAL SIGNS MONITOR

AVSM3 SNF

Owner's Manual

Please keep and refer to this Owner's Manual.

Thank you for purchasing an Attendant® Touchscreen Vital Signs Monitor from Direct Supply Equipment & Furnishings®, a division of Direct Supply, Inc. Please read this entire manual carefully and keep it for future reference. This manual will provide you with instructions, warnings, warranty information and other important information about your device. Share this information with your housekeeping, nursing and maintenance staff to help ensure the device is cared for properly.

Table of Contents

INTRODUCTION	4 - 5
Definitions & Symbols	4
Intended Use for the AVSM3 SNF	4
Indications For Use	4
About This Manual.....	5
Identifying the AVSM3 SNF Configurations.....	5
Features for the AVSM3 SNF	5
SAFETY INFORMATION	6 - 9
General Safety Information	6
Warnings.....	6 - 8
Cautions	8 - 9
DESCRIPTION OF THE MONITOR	10 - 34
Front Panel Components	10 - 13
AVSM3 SNF Controls	14
Rear Panel Components	15 - 18
Left Panel Components	19 - 22
Right Panel Components	23 - 26
Panel and Label Symbols.....	27
Displays.....	28 - 34
SETTING UP THE MONITOR	35 - 41
Unpacking and Inspection.....	35
List of Components	35
Power Cable Connections.....	36
Battery Operation	37 - 39
Measurement Cable Connections	39
External Interface.....	40 - 41
USING THE MONITOR	42 - 50
Power On/Off	42
Resident List Button	43
Locally Saved Readings Button	44
Settings Button	44 - 49
Help Button.....	50
SPOT CHECK & CONTINUOUS MODE	51 - 47
General.....	51
Changing the Mode	51
Spot Check Mode	52 - 53
Continuous Mode	53 - 54
Comparison between Spot Check Mode and Continuous Mode	55
RESIDENT MANAGEMENT	56 - 57
General.....	56
Accessing the Resident List	56
Resident List Screen Options	57
MONITORING NIBP	58 - 62
Setup Connections.....	59 - 60
Description of NIBP Operation.....	60 - 61
Principle of Measurement.....	62
MONITORING SpO₂	63 - 68
Setup Connections.....	64 - 66
Principle of measurement.....	66 - 67
Clinical Studies.....	67 - 68
CLINICAL STUDIES	70

MONITORING TEMPERATURE	71 - 78
Setup Connections.....	71 - 72
Filac 3000 Thermometer	72 - 74
ACTT-1 Thermometer	75
ACTT-1 Thermometer	76
Description of the Temp Operation.....	77
Principle of measurement.....	77
Measurement Mode	78
SAVED READINGS	79
General.....	79
Saving the Data.....	79
Management of Locally Saved Data	79
PRINTING	80
General.....	80
Measurement Data Printing.....	80
Locally Saved Data Printing.....	80
ALARMS AND LIMITS.....	81 - 85
General.....	81
Alarm Priority	81 - 82
Visual Alarm Indication.....	83
Audible Alarm Indication	83
Changing Alarm Limits.....	84 - 85
Pausing Audio Alarms/Turning Audio Alarms On/Off	85
MENU STRUCTURE	86 - 90
MAINTENANCE	91 - 93
Recycling and Disposal	91
Returning the Monitor and System Components	91
Service	91
Periodic Safety Checks	91
Cleaning	91 - 92
Battery Maintenance	92
Loading Printer Paper.....	93
TROUBLESHOOTING	94 - 96
General.....	94
Corrective Action	94 - 95
EMI (Electromagnetic Interference)	96
Obtaining Technical Assistance	96
FACTORY DEFAULTS	97 - 99
General.....	97
Parameter Ranges and Default Settings	97 - 99
SPECIFICATION	100 - 111
Display	100
Controls.....	100
Alarms.....	100
Wireless Communication.....	100
Physical Characteristics and Printer	101
Electrical Characteristics	101
Environmental Conditions	102
Alarm Tone Definition	103 - 104
Measurement Parameters	105 - 110
Manufacturer's EMC Declaration.....	111 - 115
LIMITED WARRANTY.....	118
CUSTOMER SERVICE	119

Introduction

The content of this manual is subject to change without notice. Contact Direct Supply with any questions you might have.

Definitions & Symbols

NOTE: Indicates a helpful tip.

CAUTION: Indicates correct operating or maintenance procedures in order to prevent damage to or destruction of the equipment or other property.

WARNING: Calls attention to a potential danger that requires correct procedures or practices in order to prevent personal injury.

⚠: Attention! Read the instructions.

MONITOR or Device: Your Attendant® Touchscreen Vital Signs Monitor AVSM3 SNF.

YOU and YOUR: The facility, community or other person or entity that has purchased the product.

WE, US, and OUR: Direct Supply Manufacturing, Inc.

Intended Use for the AVSM3 SNF

The monitor is intended to be used to monitor noninvasive blood pressure (NIBP) - systolic, diastolic and mean arterial pressures, functional arterial oxygen saturation (SpO₂), pulse rate (PR) and temperature (Temp) for adult residents in all areas of a hospital and hospital-type facilities. Monitor users should be skilled at the level of a technician, doctor, nurse or medical specialist. The vital sign monitor AVSM3 SNF is suitable for spot checks as well as continuous measurement.

NOTE: *Hospital use typically includes general care floors, operating rooms, special procedure areas, intensive and critical care area within the hospital. Hospital-type facilities include ambulance, physician office-based facilities, sleep labs, skilled nursing facilities, surgical centers, and sub-acute care centers.*

NOTE: *The medically skilled and trained user can be clinicians like doctors and nurses who know how to take and interpret a resident's vital signs. These clinicians must take direct responsibility for the resident's life. This can include care-givers or medically trained interpreters who are authorized under the appropriate clinical facility procedures to support resident care. Any inappropriate setting, especially the alarm limit or alarm notification settings, can lead to a hazardous situation that injures the resident, harms the resident, or threatens the resident's life. This equipment should only be operated by trained users who can adjust the settings of the vital signs monitor.*

Indications For Use

	Indications	Contraindications
Noninvasive Blood Pressure	Noninvasive blood pressure monitoring is intended for detection of hypertension or hypotension and monitoring BP trends in resident conditions.	Noninvasive blood pressure is not intended for use with severe arrhythmia. Noninvasive blood pressure monitoring is not intended for residents who are experiencing convulsion or tremors.
Pulse Oximetry	Pulse oximetry monitoring is intended to be used to monitor functional arterial oxygen saturation and pulse rate.	Pulse oximetry monitoring is not intended for use with severe peripheral vascular disease and severe anemia (decreased hemoglobin).
Temperature	Temperature monitoring is indicated for use in residents who require continuous monitoring of body temperature.	No known contraindications

About This Manual

This manual explains how to set up and use the monitor.

Read the entire manual including the *Safety Information* section, before you operate the monitor.

Identifying the AVSM3 SNF Configurations

The following table identifies AVSM3 SNF configurations and how they are indicated. The reference number and serial number are located on the bottom of the monitor.

All information in this manual, including the illustrations, is based on the monitor configured with the SunTech NIBP module, Battery, Nellcor/MD1 SpO₂ module, Printer module, Exergen/Filac 3000/ACTT-1/ACTT-1 thermometer, or Bluetooth communication module. If the relevant functions do not exist, please verify your unit configuration.

Reference Number

Product Brand	dash	Battery Pack	Printer Module	Communication Module	SpO ₂ Module	Temp Module	National Code
AVSM3 SNF	-	3	P X	B X	N C	F T A, B, D, E	U

NOTE: The first character can be P or X depending on whether the installed printer. (P: Printer, X: Not installed)

NOTE: The second character can be B or X, depending on whether the Bluetooth communication module is installed. (B: Bluetooth, X: Not installed)

NOTE: The third character is N or C, depending on which SpO₂ module is installed (N: Nellcor SpO₂, C: MD1 SpO₂)

NOTE: The fourth character can be F or T, depending on the temperature module installed (F: Filac 3000, T: Exergen), A: ACTT-1, B: ACIT-1, D: Dual Temp Filac 3000 + ACTT-1, E: Dual Temp Filac 3000 + ACIT-1. For example, AVSM3 SNF-3XBNTU means the following configuration: AVSM3 SNF + 3S3P battery pack + no printer + Bluetooth + Nellcor SpO₂ module + Exergen temperature module + US region code

Features for the AVSM3 SNF

Physical

The monitor is lightweight and compact vital signs monitor measuring 249 × 211 × 176 (mm) (W×H×D) for Standard configuration and weighting 3.1 kg. Its carrying handle is designed for instrument transport while battery-powered monitoring.

Electrical

The monitor is powered by an internal battery pack that typically provides 8 hours of monitoring from a fully charged new battery. The batteries are continuously recharged when the monitor

is connected to AC power source. Refer to the **Battery Operation** section for details.

Display

The monitor display is a color LCD touch screen that shows numeric resident vitals information as well as device status conditions.

Auxiliary Input / Output(s)

The monitor provides USB ports, RJ11 port as standard outputs. Bluetooth is also available as a standard output.

Safety Information

General Safety Information

This section contains important safety information related to general use of the AVSM3 SNF. Other important safety information appears throughout the manual. The AVSM3 SNF will be referred to as the monitor throughout this manual.

Important! Before use, carefully read this manual, accessory directions for use, all precautionary information and specifications.

Warnings

Warnings alert you to potential serious outcomes (death, injury, or adverse events) to the resident or user.

⚠ WARNING	Do not take into or use the monitor in locations where highly combustible anesthetics or flammable gases are used or in high-pressure oxygen rooms or inside oxygen tents, as this may cause a flammable explosion.
⚠ WARNING	When using the monitor with a commercial electric power source, use the monitor with an electric power wall socket with a grounding wire for medical use. Not doing so could cause electric shock.
⚠ WARNING	Do not connect grounding wire to gas pipes. This could cause fire.
⚠ WARNING	Only doctors and officially certified personnel should use this monitor. Do not allow residents to touch this monitor. Allowing residents to touch this monitor could cause accidents.
⚠ WARNING	This monitor cannot be used when MRI is in progress. If MRI is in use, keep resident attachments away from residents to prevent accidents.
⚠ WARNING	The monitor conforms to the requirements of the EMC standard (IEC60601-1-2), and may therefore be used simultaneously with pacemakers and other electrical simulators. It should, however, be noted that the monitor may be affected by electrical scalpels and microwave therapeutic apparatus. Please check operation of the monitor during and after use of such equipment.
⚠ WARNING	Do not take mobile phones or transceivers into a room where this monitor is installed, as such devices may cause accidents.
⚠ WARNING	In order to avoid accidents, do not use any unauthorized accessories or options.
⚠ WARNING	Thoroughly read the instruction manuals supplied with accessories and options to ensure correct use. This instruction manual does not carry the caution selections for such equipment.
⚠ WARNING	Do not open cover or disassemble this monitor. Doing so could cause electric shock or fire. It is prohibited by law to modify the monitor without authorization.
⚠ WARNING	Do not use power source other than the specified voltage, (100-240V~50/60Hz) as this may cause fire or electric shock.
⚠ WARNING	Pre-use inspection and preventive maintenance must be performed for safe use.
⚠ WARNING	The monitor may be used with electrical surgical equipment. Follow the instruction manuals for medical instruments – notably electrosurgical and diathermy instruments – when used, as their high-frequency energy units may cause burns to residents via attachments.

⚠ WARNING	This monitor is protected against the discharge of a defibrillator. However, do not touch the monitor when a defibrillator is being discharged (electrified), as doing so may cause electric shock.
⚠ WARNING	The following cautions apply when connecting the monitor with other equipment. <ol style="list-style-type: none"> 1. Ensure that the connected equipment is in accordance with the IEC60601-1 or IEC safety standards, so that the system complies with IEC60601-1. 2. Employ additional protective measures (e.g. additional protective earthing) as necessary.
⚠ WARNING	Do not connect devices that do not meet medical safety standards (such as commercial PCs), as they may cause electric shock. This monitor meets the restricted level of leakage required for medical devices. Therefore, this monitor cannot be connected to a device that would give a combined total of leakage beyond the restricted level.
⚠ WARNING	Do not place anything on top of this monitor. If something is spilled over the monitor or gets into it, such spillage may cause fire or electric shock. If fluid spills on the monitor accidentally, disconnect power cord, wipe dry immediately, and have the monitor serviced to make sure that no hazard exists.
⚠ WARNING	Do not place heavy objects on the power cord, as doing so may cause fire or electric shock.
⚠ WARNING	Before conducting maintenance work, turn the power OFF and unplug the power cord from the wall socket to prevent electric shock.
⚠ WARNING	When the following occur, turn the power OFF immediately and unplug the power cord from the wall socket. Continued use in such situations may cause fire or electric shock. <ul style="list-style-type: none"> • There is smoke or a strange odor leaking out of the monitor. • The monitor has been dropped or impacted by an object. • Liquid or foreign matter gets inside the monitor. • Device failure has occurred. <p>Also, when any of the above occurs, promptly do the following:</p> <ol style="list-style-type: none"> 1. Check to see that the power cord has been unplugged from the wall socket. 2. Place an "Out of Order" sign on the monitor and do not use it.
⚠ WARNING	Do not connect more than one resident to the monitor. Do not connect more than one monitor to a resident.
⚠ WARNING	The vital signs monitor is a prescription device and is to be operated by qualified personnel only.
⚠ WARNING	As with any medical equipment, carefully route resident cabling to reduce the possibility of resident entanglement or strangulation.
⚠ WARNING	Never lift the monitor by the sensor cable, blood pressure hose, power cord, or any other accessory. Such accessories could detach, causing the monitor to fall on the resident.
⚠ WARNING	Do not position the monitor so it is difficult to operate the disconnection device when a separable plug is used as isolation.
⚠ WARNING	Do not touch signal input, signal output or other connectors, and the resident simultaneously.

Safety Information *(cont.)*

⚠ WARNING	The monitor may remain attached to the patient during defibrillation or during use of an electrosurgical unit; the monitoring system is defibrillator-proof, however, readings may be inaccurate during defibrillation and shortly thereafter.
⚠ WARNING	Do not cover the vent holes to not to generate heat matter.
⚠ WARNING	Do not cover the speaker.
⚠ WARNING	Keep the monitor out of reach of babies and children to avoid any accidents.
⚠ WARNING	The monitor might be damaged due to improper grounding of electrosurgical equipment when the monitor is used with an electrosurgical equipment.
⚠ WARNING	In order to avoid accidents, do not use the leadwire or a probe if its cable is damaged.
⚠ WARNING	In order to avoid accidents, do not use the device if cables, device, or connectors are damaged.
⚠ WARNING	Ensure a minimum distance between portable and mobile RF communications equipment (transmitters) and the monitor are maintained.
⚠ WARNING	 The monitor is significantly ferromagnetic and pose a clear and direct threat to user and/or patient and equipment within the magnet room.

NOTE: AVSM3 SNF meets electromagnetic interference standards.

Cautions

Caution statements identify conditions or practices that could result in damage to the equipment or other property.

⚠ CAUTION	Federal law restricts this device to sale by or on the order of a physician.
⚠ CAUTION	The monitor may not operate properly if it is operated or stored at conditions outside the ranges stated in this manual, or subjected to excessive shock or dropping.
⚠ CAUTION	When connecting the vital signs monitor to any instrument, verify proper operation before clinical use. Both the monitor and the instrument connected to it must be connected to a grounded outlet.
⚠ CAUTION	Accessory equipment connected to the monitor's data interface must be certified according to IEC60950 for data-processing equipment or IEC60601-1 for electromedical equipment. All combinations of equipment must be in compliance with IEC60601-1 system requirements. Anyone who connects additional equipment to the signal input or signal output port configures a medical system and is therefore responsible that the system complies with the requirements of IEC 60601-1 and the electromagnetic compatibility system standard IEC60601-1-2. If in doubt, consult Direct Supply Technical Support Representative.
⚠ CAUTION	Risk of explosion if battery is replaced with an incorrect type.
⚠ CAUTION	Where the integrity of the external protective conductor in the installation or its arrangement is in doubt, equipment shall be operated from its internal electrical power source.
⚠ CAUTION	Do not rely entirely on the monitor readings for resident clinical assessment.

⚠ CAUTION	Pulling the cable could cause the disconnection of the cable from the monitor and can cause the error for the measurement.
⚠ CAUTION	The battery may be depleted due to self-discharge for a long storage. Recharge the battery when the device is initially installed.
⚠ CAUTION	The partial charge of a battery results in a shortened battery life.
⚠ CAUTION	The existence of obstacles (such as wall) will exert impact on data transferring or even cause network interruption.
⚠ CAUTION	Check the network connection status before use.
⚠ CAUTION	If wireless network signal is poor, there may be a risk of CMS-destined data loss.
⚠ CAUTION	If there are any problems with the network connection, contact the service personnel and ensure that the monitor IP address settings is correct. Changing the network settings may result in network disconnection.
⚠ CAUTION	RF Interference may result in wireless network disconnection.

Description of the Monitor

Front Panel Components

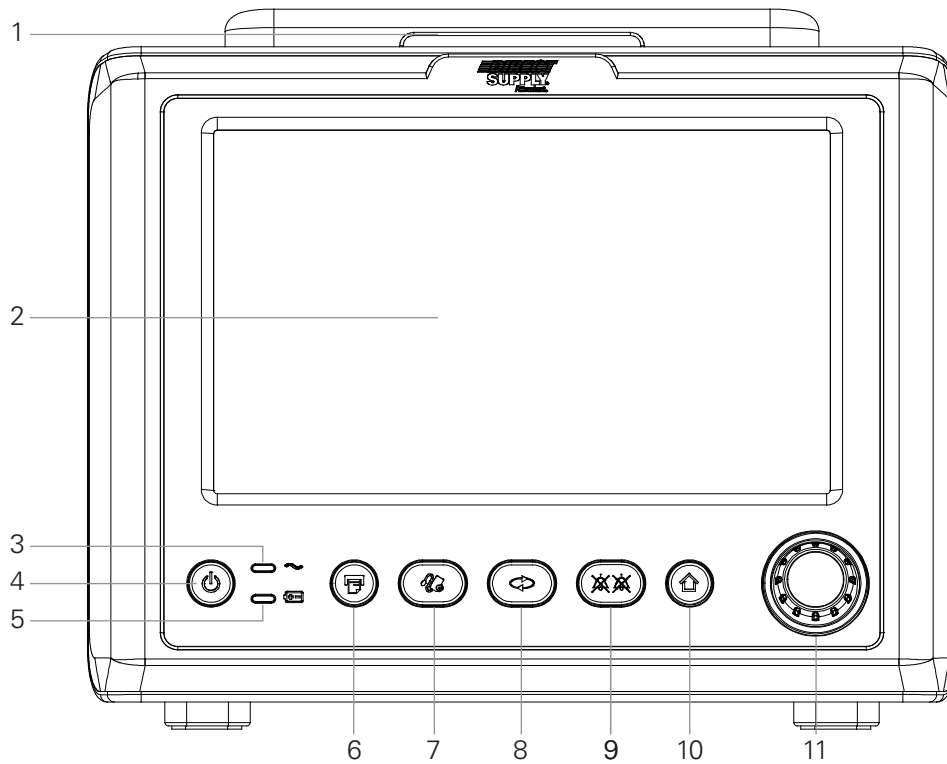

Figure 1. Front Panel Components

- | | | | |
|---|-------------------------|----|------------------------------|
| 1 | Alarm Window | 7 | NIBP Start/Stop Button |
| 2 | LCD (Touch) | 8 | NIBP Interval Setting Button |
| 3 | AC Power Indicator | 9 | Audio Alarm Pause/Off Button |
| 4 | Power Button | 10 | Home Button |
| 5 | Battery Indicator | 11 | Knob |
| 6 | Print Start/Stop Button | | |

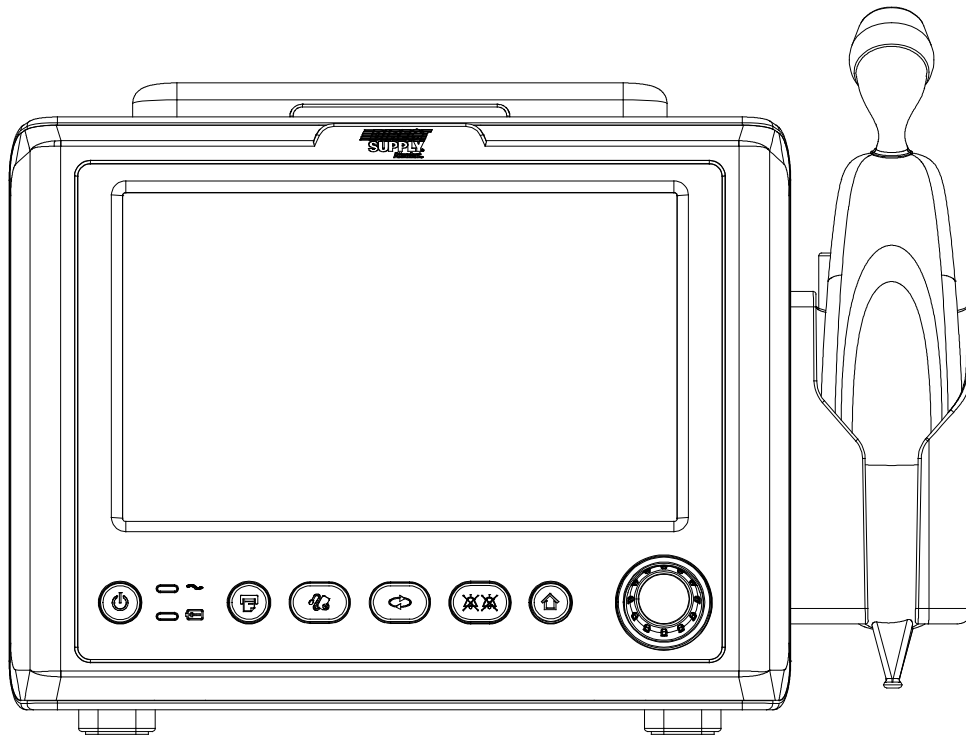

Figure 2. Front Panel Components (Exergen Thermometer option is installed)

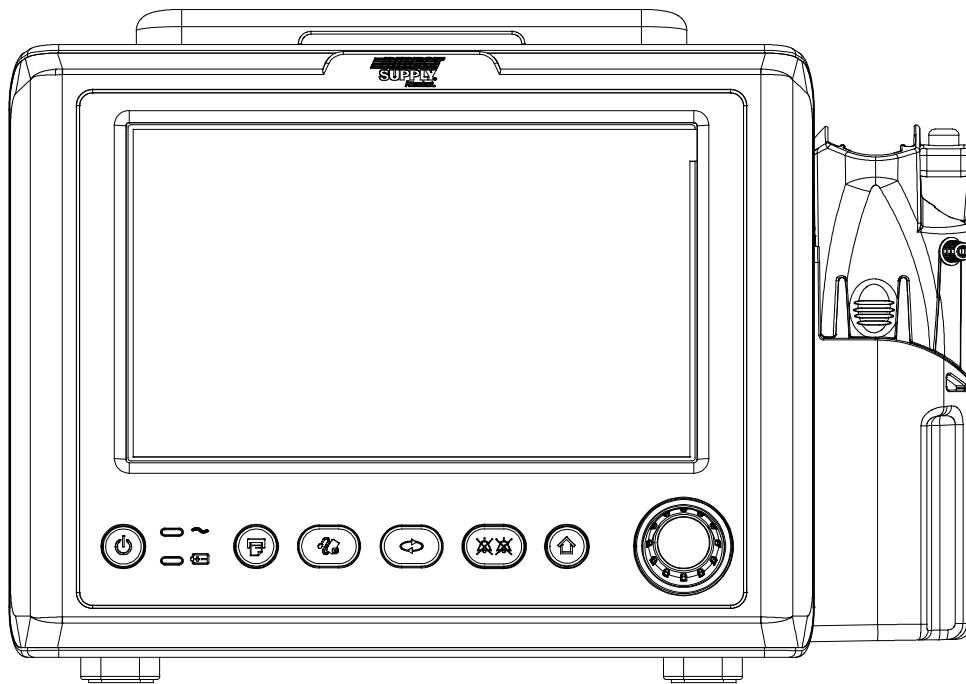

Figure 3. Front Panel Components (Filac 3000 Thermometer option is installed)

Description of the Monitor *(cont.)*

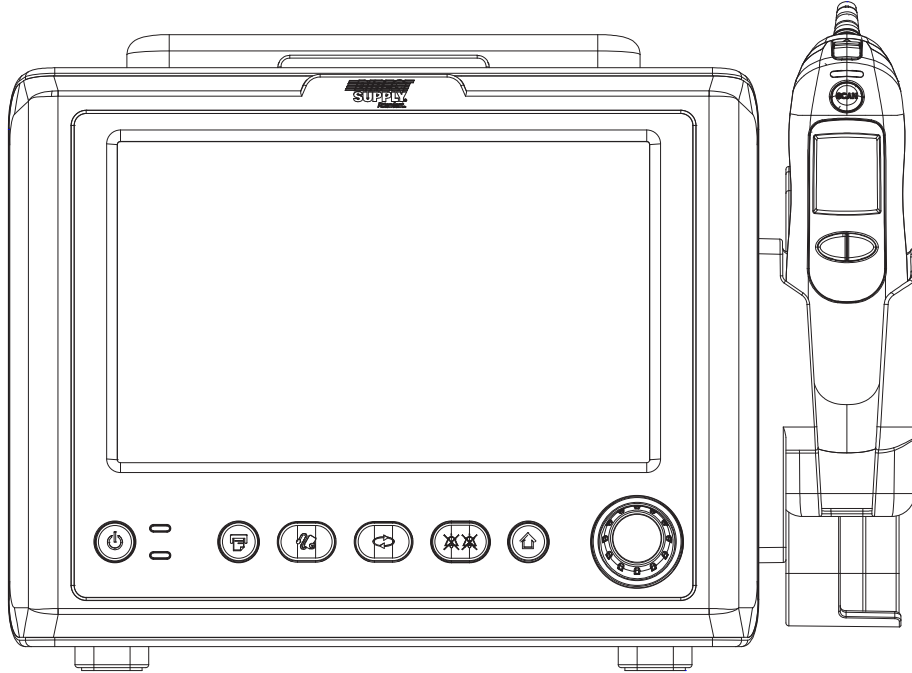

Figure 4. Front Panel Components (ACTT-1 Thermometer option is installed)

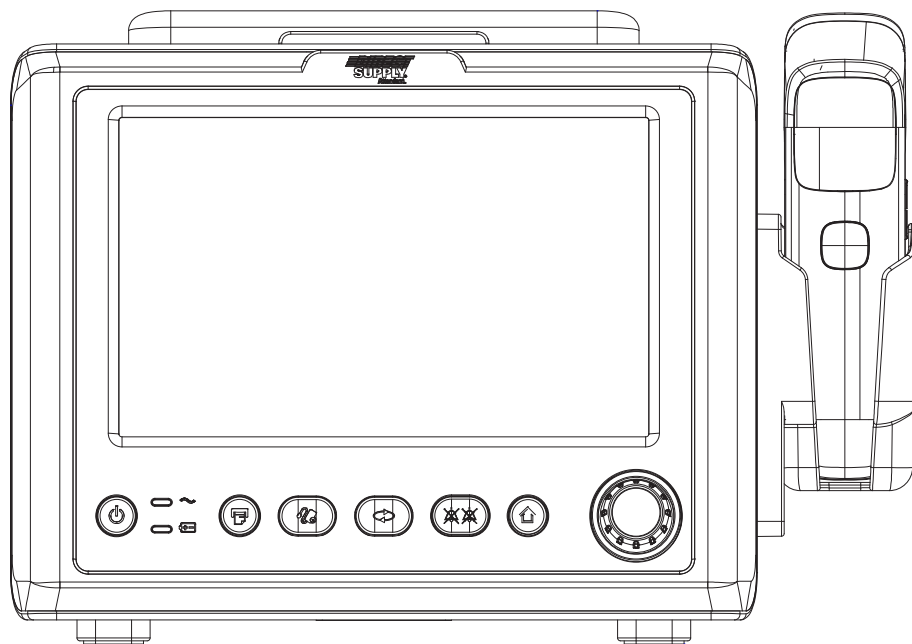

Figure 5. Front Panel Components (ACIT-1 Thermometer option is installed)

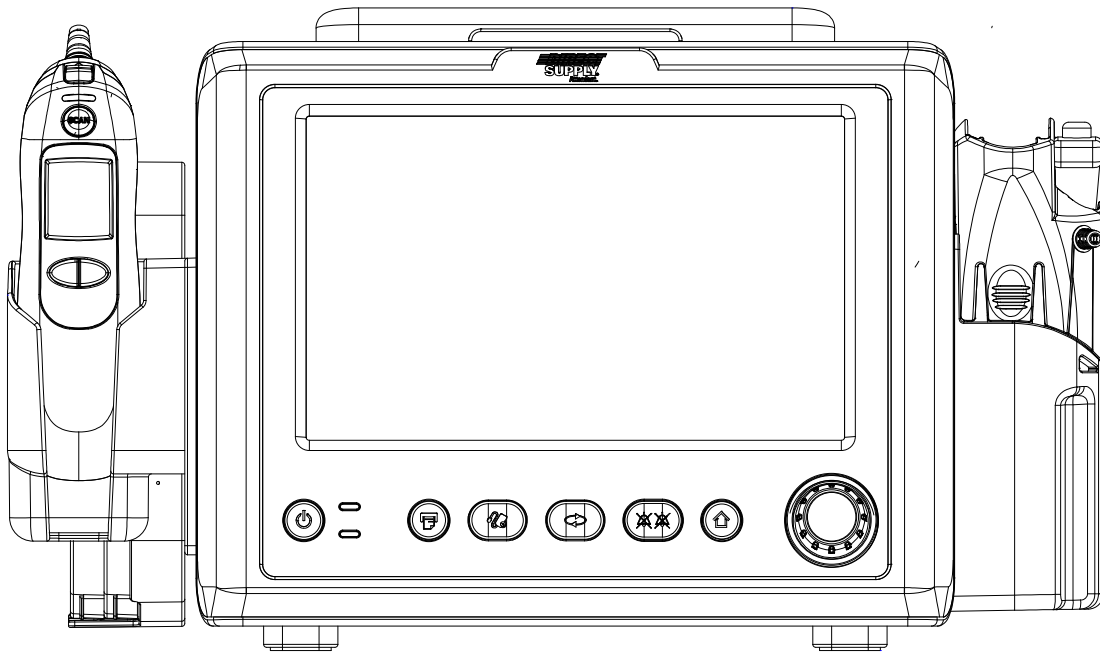

Figure 6. Front Panel Components (Filac 3000 & ACTT-1 Thermometer option is installed)

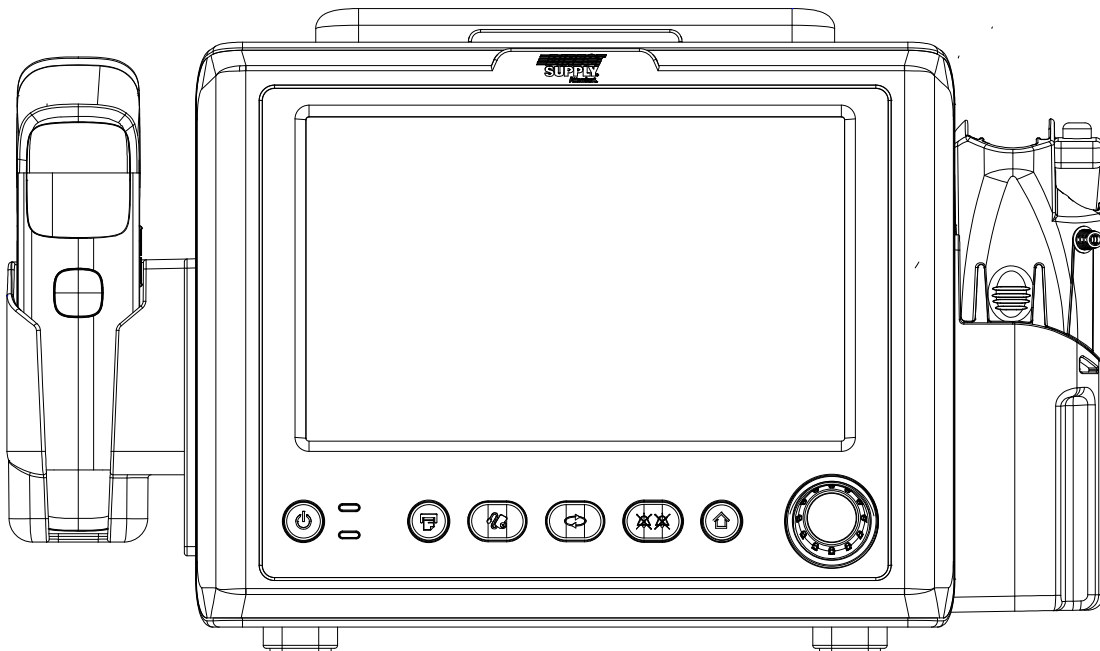









Figure 7. Front Panel Components (Filac 3000 & ACIT-1 Thermometer option is installed)

Description of the Monitor *(cont.)*

AVSM3 SNF Controls

Controls	Description
	Power Button Turn on the monitor by pressing and holding the Power Button for approximately 1 second. Turn off the monitor by pressing and holding the Power Button for approximately 1 second.
	Print Start/Stop Button Print measured data if an optional printer is installed.
	NIBP Start/Stop Button Initiate NIBP measurement when pressed. If the NIBP Start/Stop Button is pressed again during the measurement, it will stop the measurement process and deflate the cuff.
	NIBP Interval Setting Button Displays the NIBP interval setting.
	Audio Alarm Pause/Off Button Pause the audio alarm on the monitor, or mutes an active audio alarm.
	Home Button Return to the home screen.
	Knob Move the area on the display in order when rotate the Knob . Operates in the same manner as a screen touch when the Knob is pressed.

Rear Panel Components

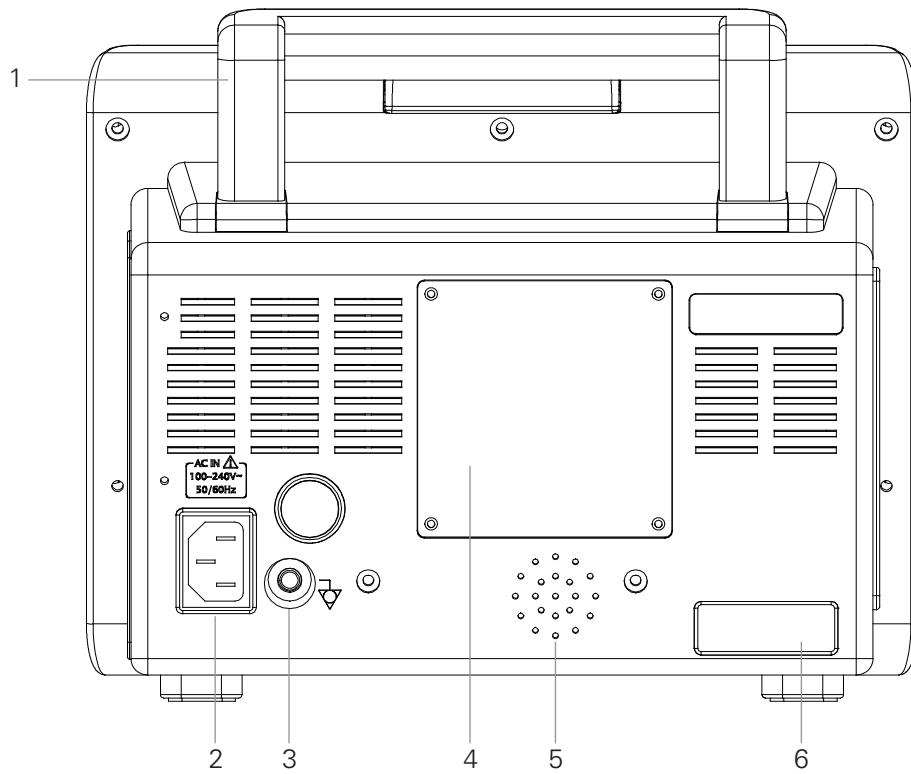

Figure 8. Rear Panel Components

- | | | | |
|---|---------------------------------|---|-------------------------------|
| 1 | Handle | 4 | Battery Cover |
| 2 | AC Power Connector | 5 | Speaker |
| 3 | Equipotential Terminal (Ground) | 6 | External Communication Module |

Description of the Monitor (cont.)

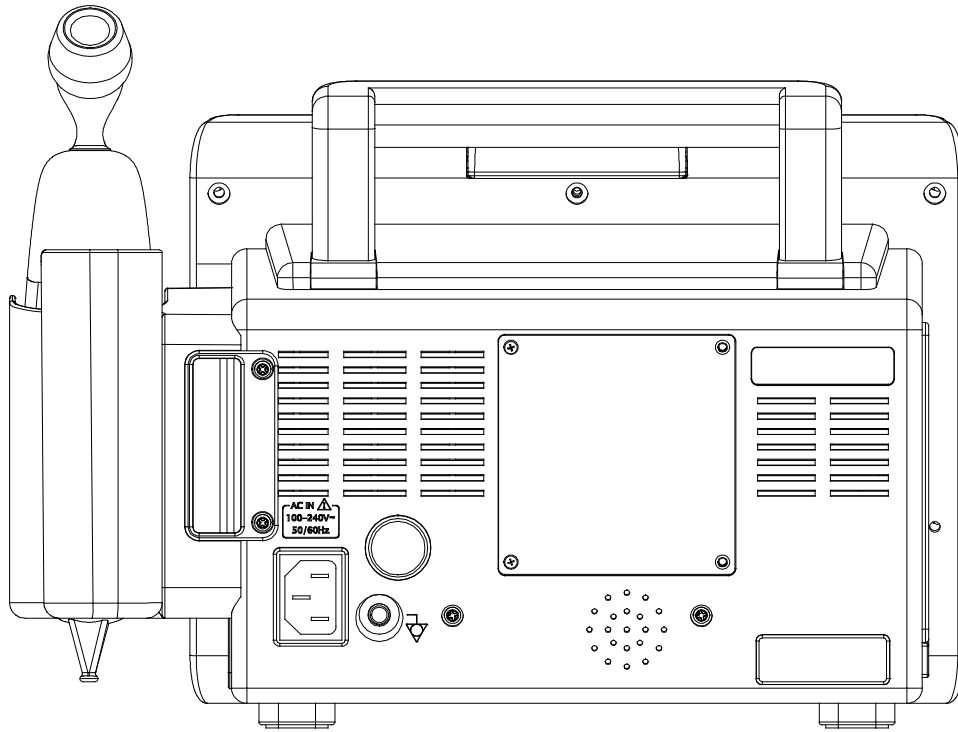

Figure 9. Rear Panel Components (Exergen Thermometer option is installed)

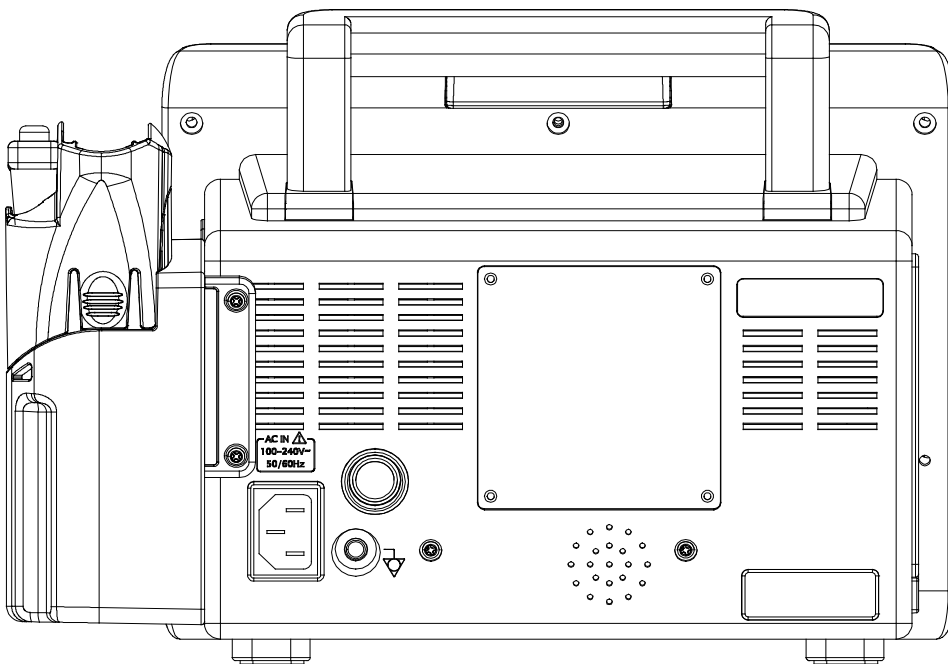

Figure 10. Rear Panel Components (Filac 3000 Thermometer option is installed)

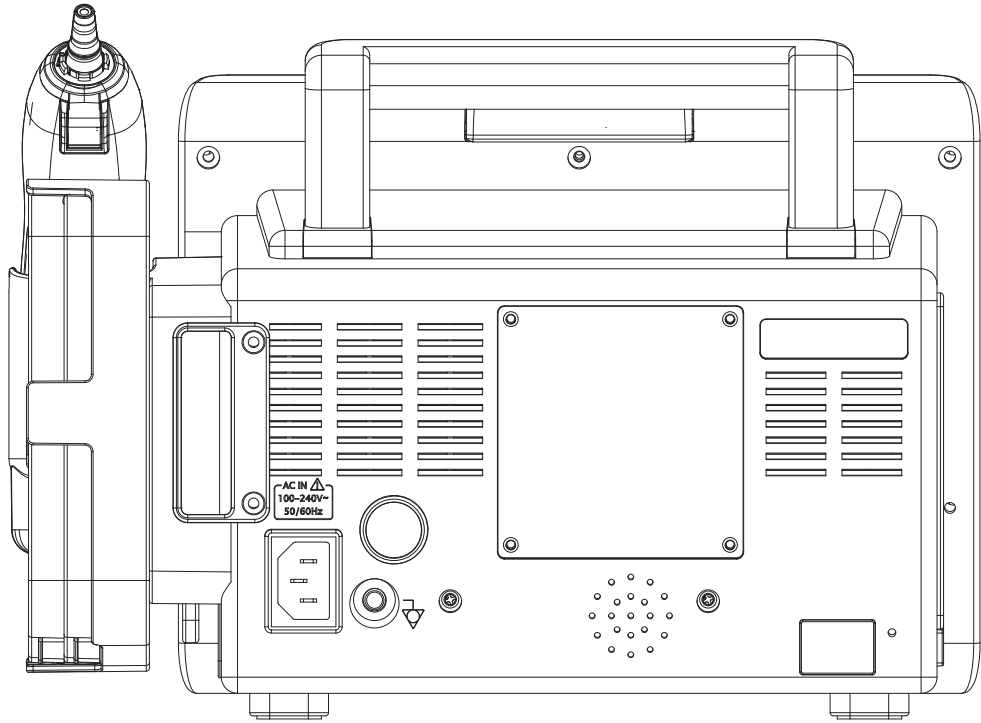

Figure 11. Rear Panel Components (ACT-1 Thermometer option is installed)

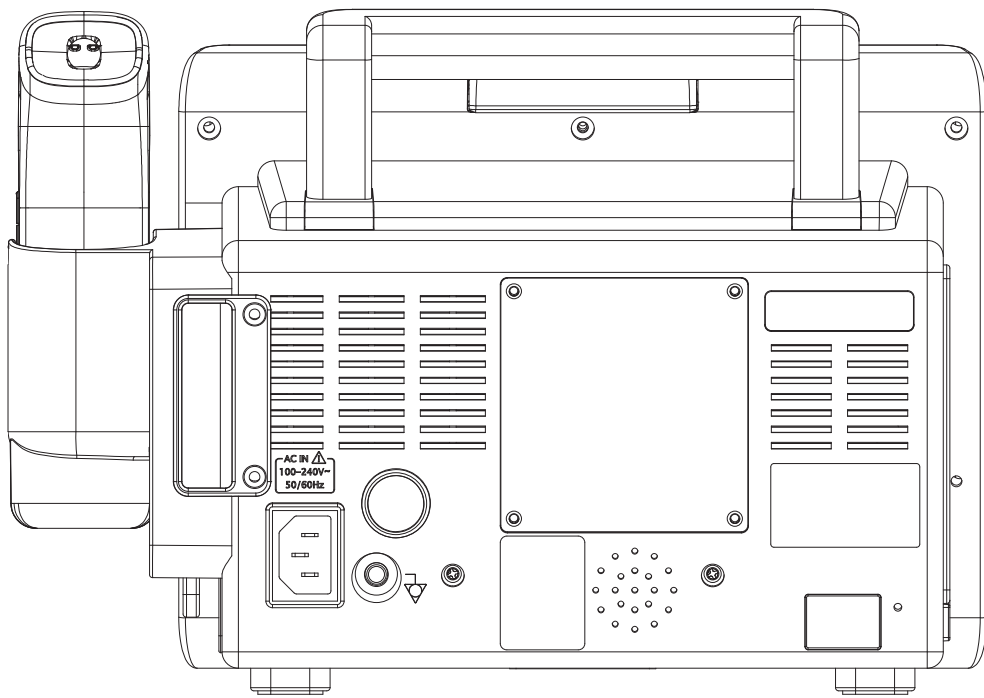

Figure 12. Rear Panel Components (ACT-1 Thermometer option is installed)

Description of the Monitor *(cont.)*

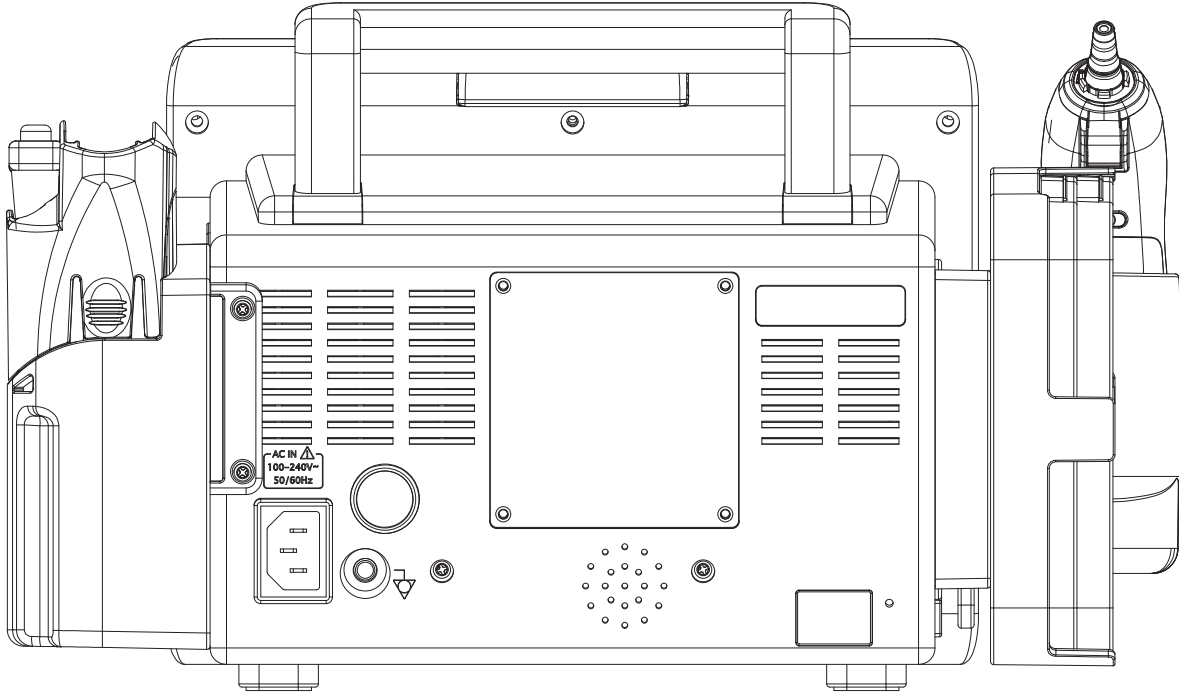

Figure 13. Rear Panel Components (Filac 3000 & ACTT-1 Thermometer option is installed)

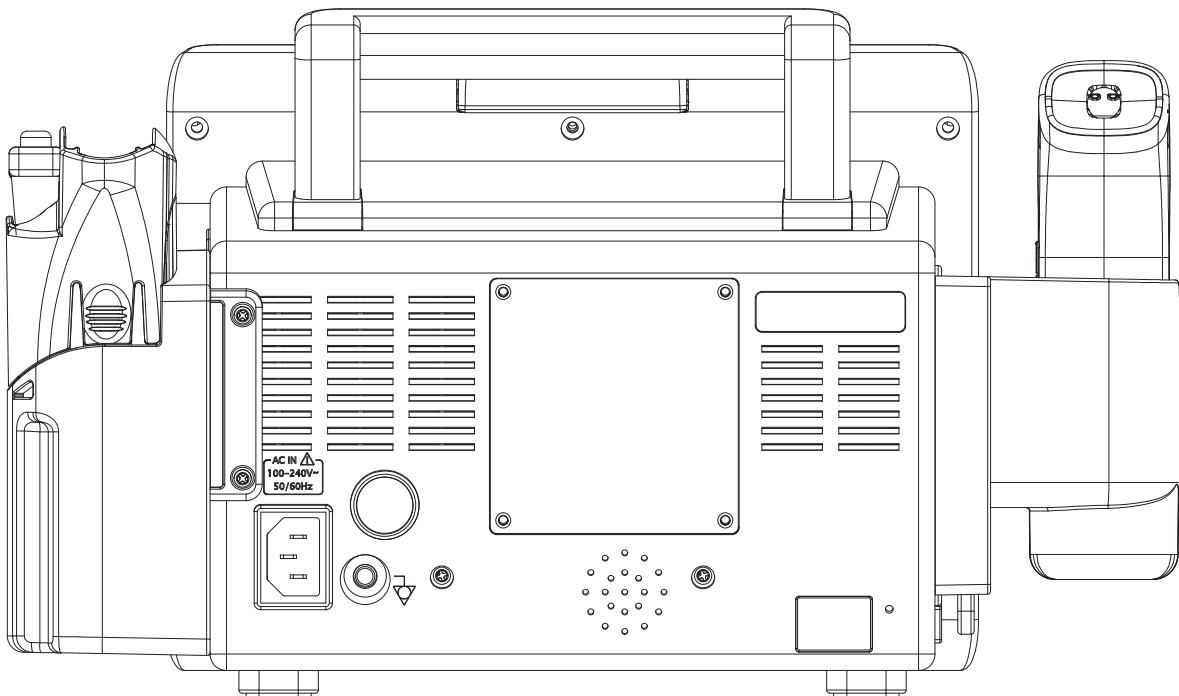
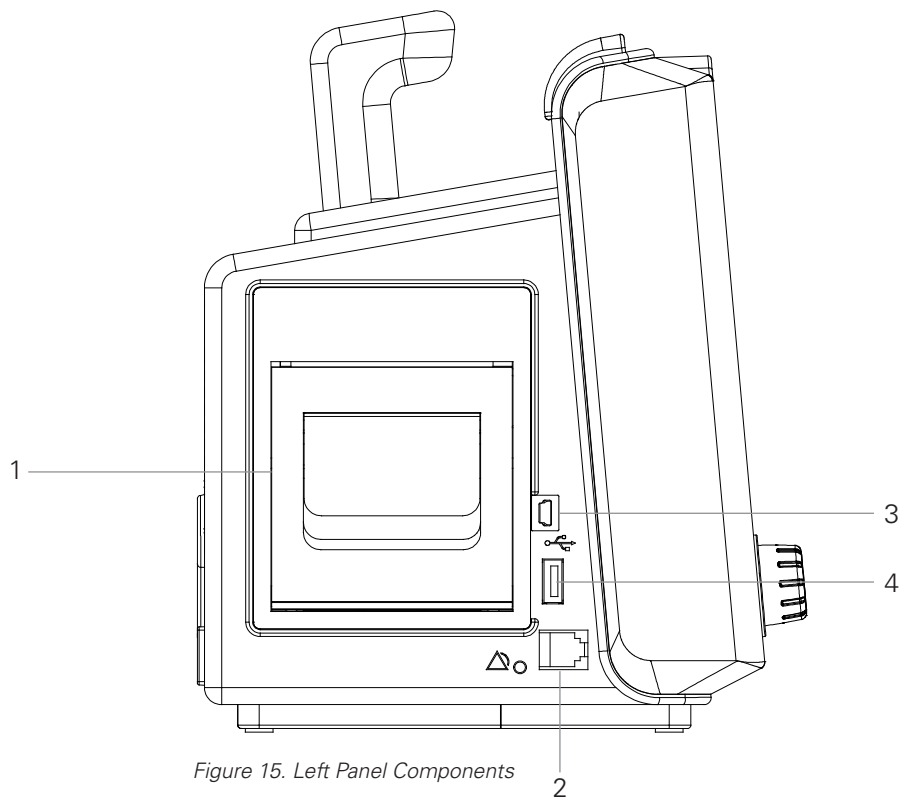

Figure 14. Rear Panel Components (Filac 3000 & ACIT-1 Thermometer option is installed)

Left Panel Components



- 1 Printer
- 2 Nurse call Port (RJ11 Type)
- 3 USB Port (mini USB B Type)
- 4 USB Port (USB A Type)

Description of the Monitor *(cont.)*

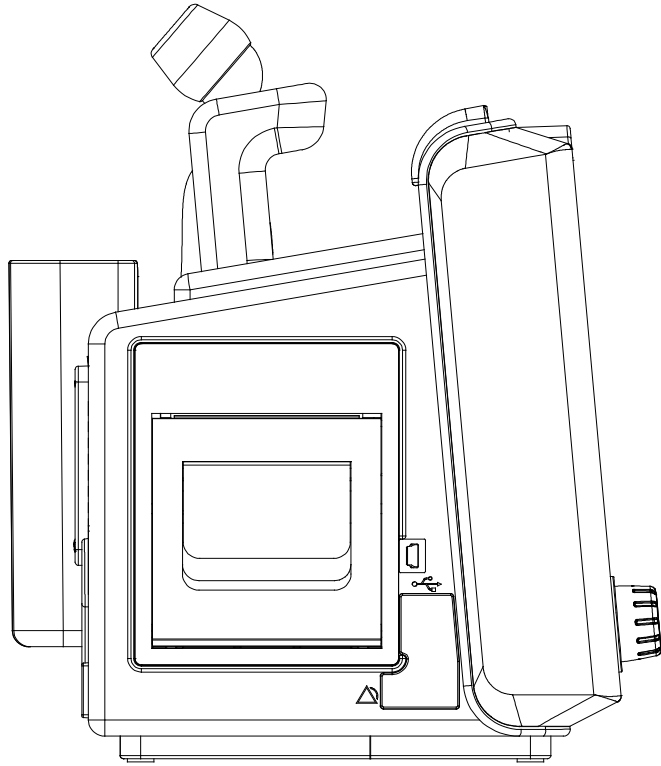

Figure 16. Left Panel Components (Exergen Thermometer option is installed)

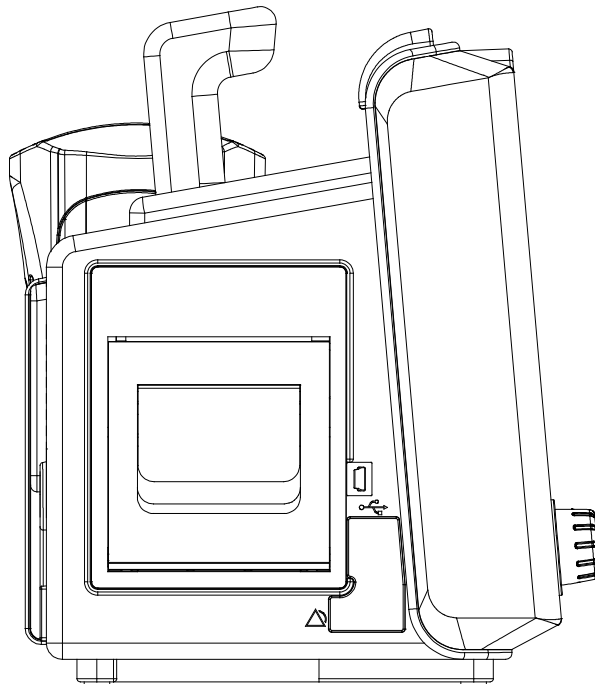

Figure 17. Left Panel Components (Filac 3000 Thermometer option is installed)

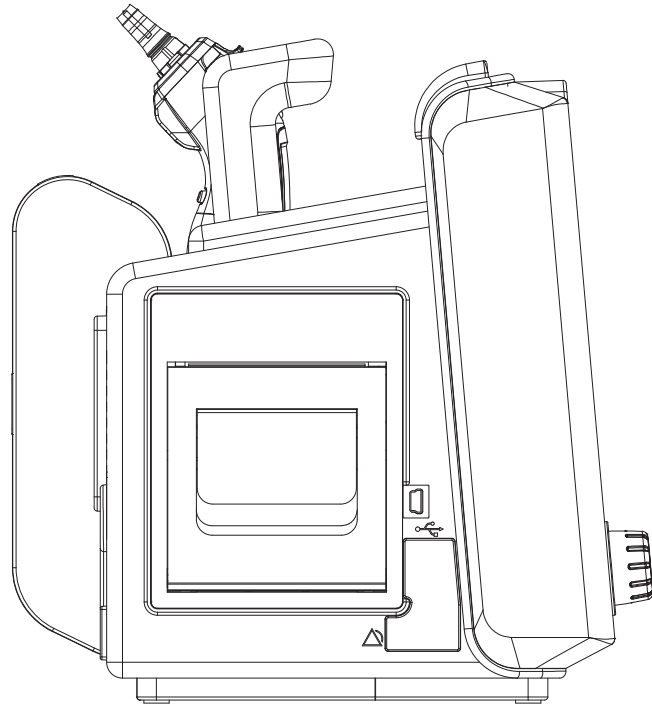

Figure 18. Left Panel Components (ACTF-1 Thermometer option is installed)

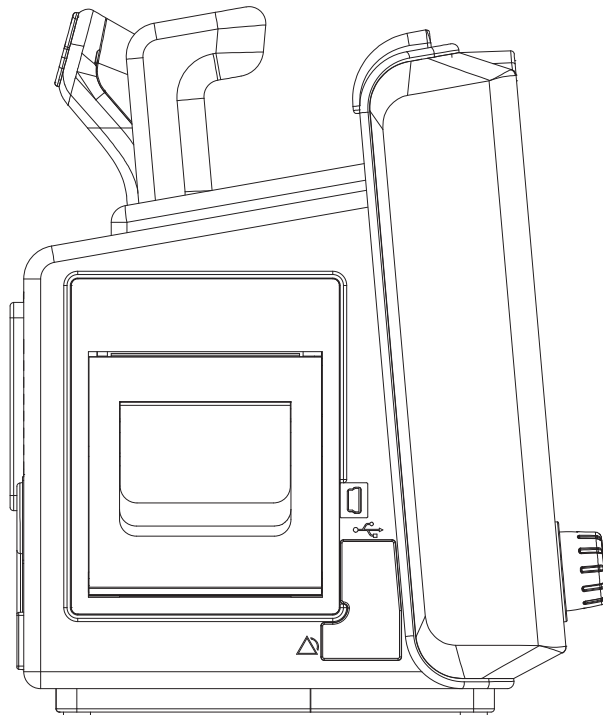

Figure 19. Left Panel Components (ACTF-1 Thermometer option is installed)

Description of the Monitor *(cont.)*

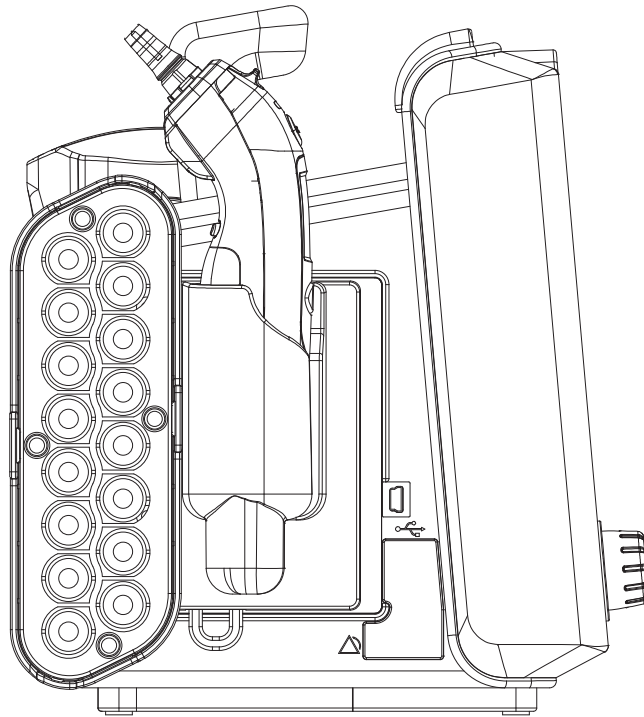

Figure 20. Left Panel Components (Filac 3000 & ACTT-1 Thermometer option is installed)

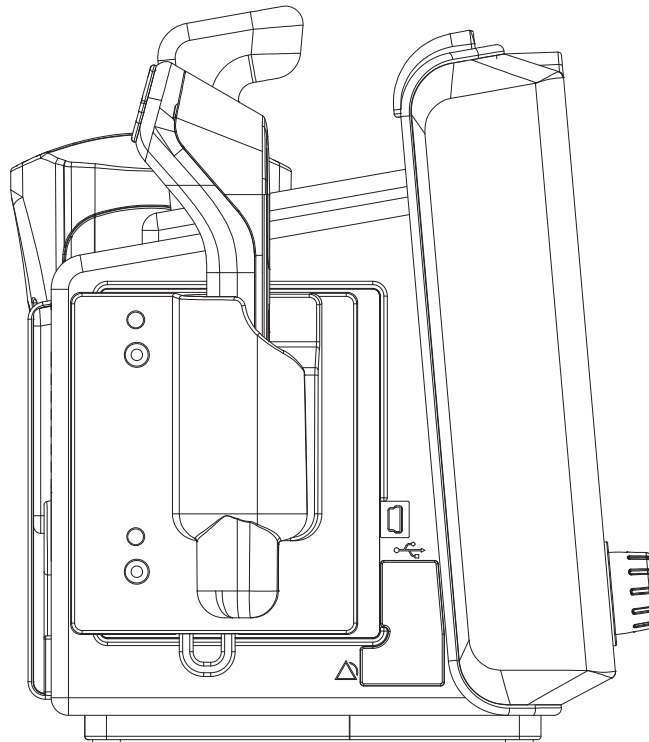

Figure 21. Left Panel Components (Filac 3000 & ACIT-1 Thermometer option is installed)

Right Panel Components

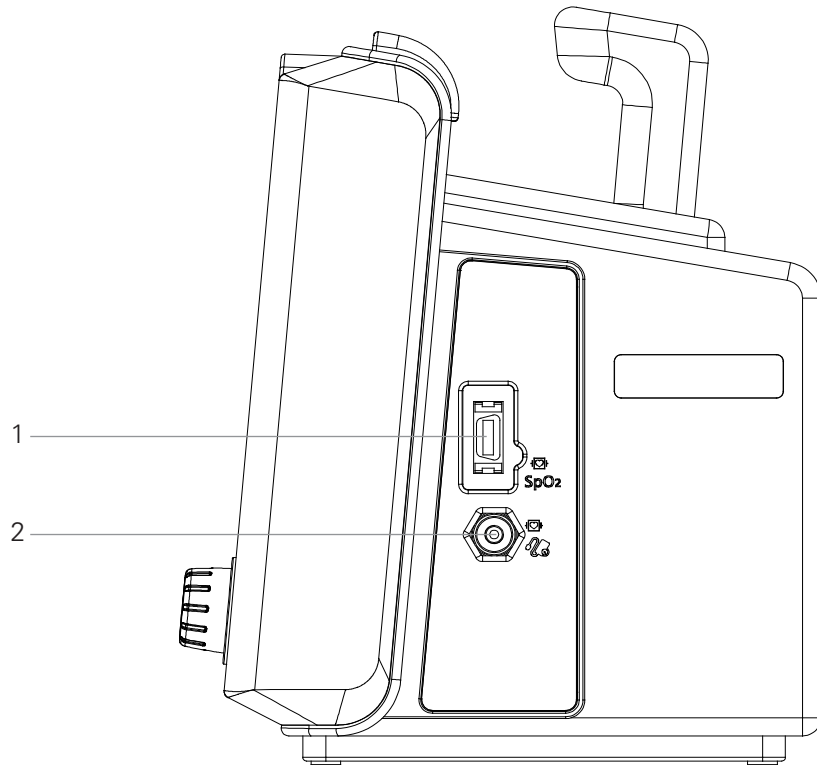

Figure 22. Right Panel Components

- 1 SpO₂ Connector
- 2 NIBP Connector

Description of the Monitor (cont.)

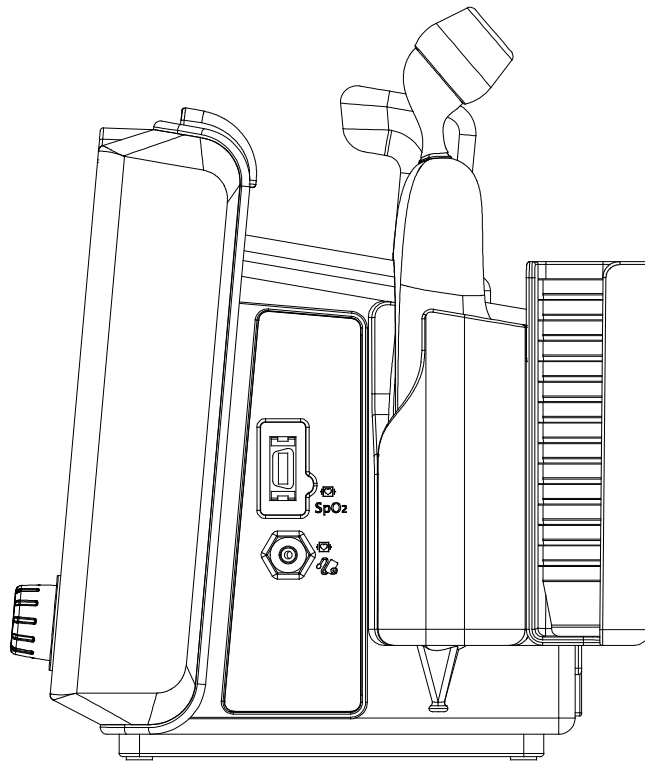

Figure 23. Right Panel Components (Exergen Thermometer option is installed)

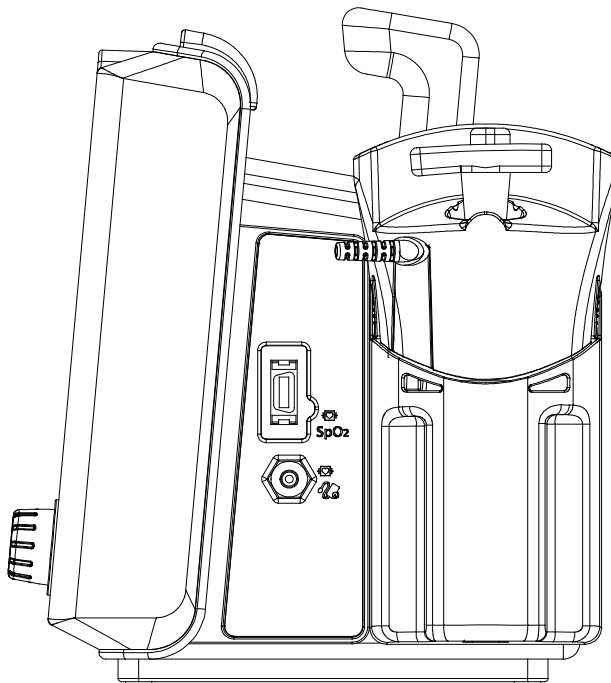

Figure 24. Right Panel Components (Filac 3000 Thermometer option is installed)

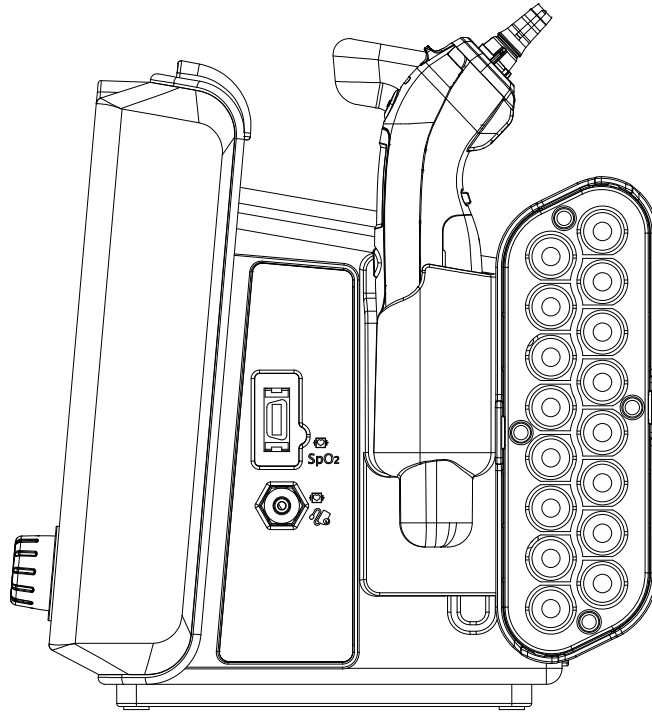

Figure 25. Right Panel Components (ACTF-1 Thermometer option is installed)

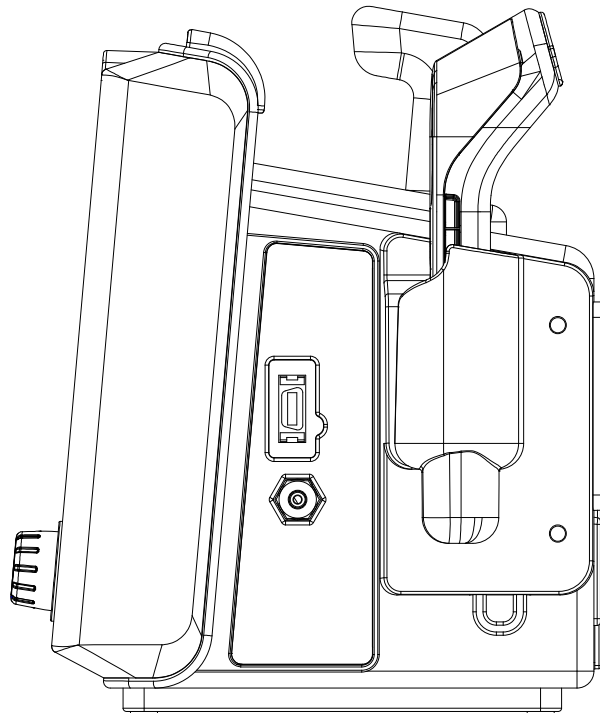

Figure 26. Right Panel Components (ACIT-1 Thermometer option is installed)

Description of the Monitor *(cont.)*

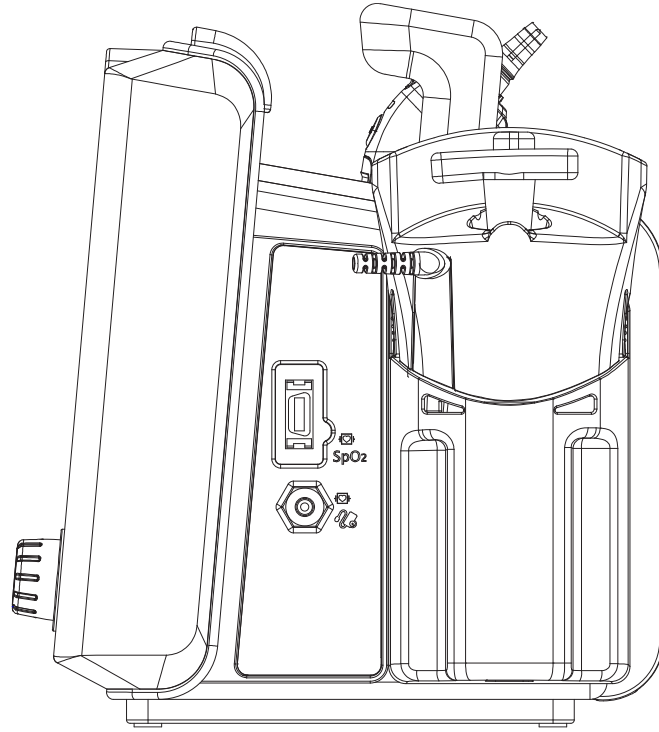

Figure 27. Right Panel Components (Filac 3000 & ACTF-1 Thermometer option is installed)

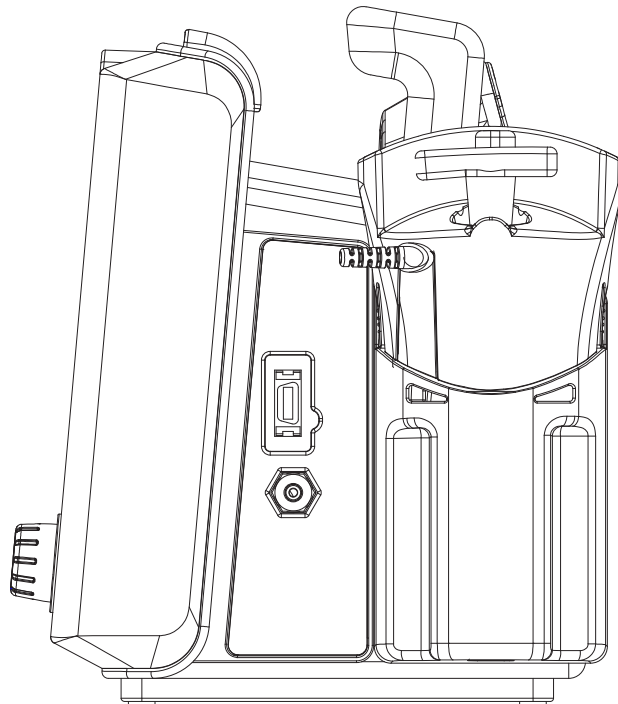





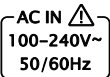





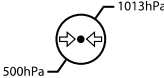

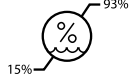
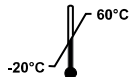











Figure 28. Right Panel Components (Filac 3000 & ACIF-1 Thermometer option is installed)

Panel and Label Symbols

Symbols	Description	Symbols	Description
	Battery Charging indicator		EU representative
	AC power indicator		Dust and water resistance
	Equipotential stud		Follow instructions for use
	AC power input rating		Disposal instructions
	Type CF- Defibrillator proof		Manufacturer
	Type BF- Defibrillator proof		Date of manufacture
	Type BF		Environmental shipping/storage atmospheric limitations
	NIBP connector		Environmental shipping/storage humidity limitations
SpO₂	SpO ₂ connector		Environmental shipping/storage temperature limitations
	Temp connector		Fragile-handle with care
	USB A and Mini USB B type		This way up
	Nurse call signal symbol		Keep dry
	Reference number		⚠ CAUTION: Federal law restricts this device to sale by or on the order of a physician.
	Serial number		

Description of the Monitor *(cont.)*

Displays

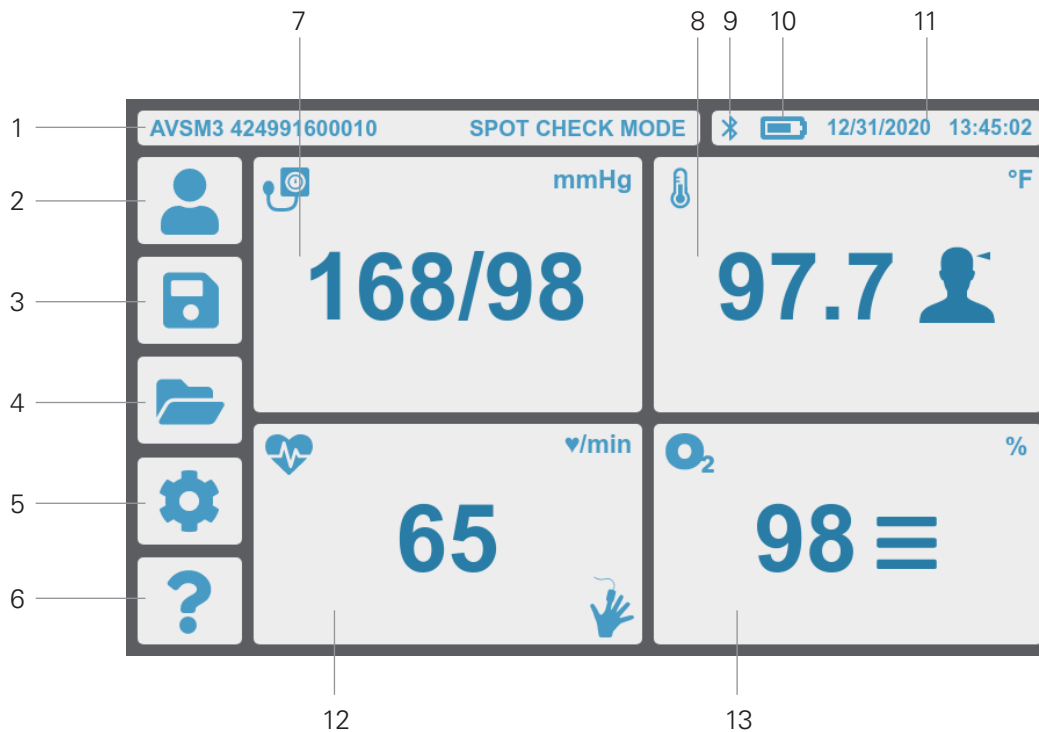

Figure 29. Home Screen (with 5 buttons)

- | | | | |
|---|-------------------------------|----|------------------------|
| 1 | Message/Mode Tile | 8 | Temperature Tile |
| 2 | Resident List Button | 9 | Bluetooth Indicator |
| 3 | Save Button | 10 | Power Status Indicator |
| 4 | Locally Saved Readings Button | 11 | Date/Time Tile |
| 5 | Settings Button | 12 | Pulse Rate Tile |
| 6 | Help Button | 13 | SpO ₂ Tile |
| 7 | NIBP Tile | | |

NOTE: The display may differ depending on the monitor configuration, or mode.

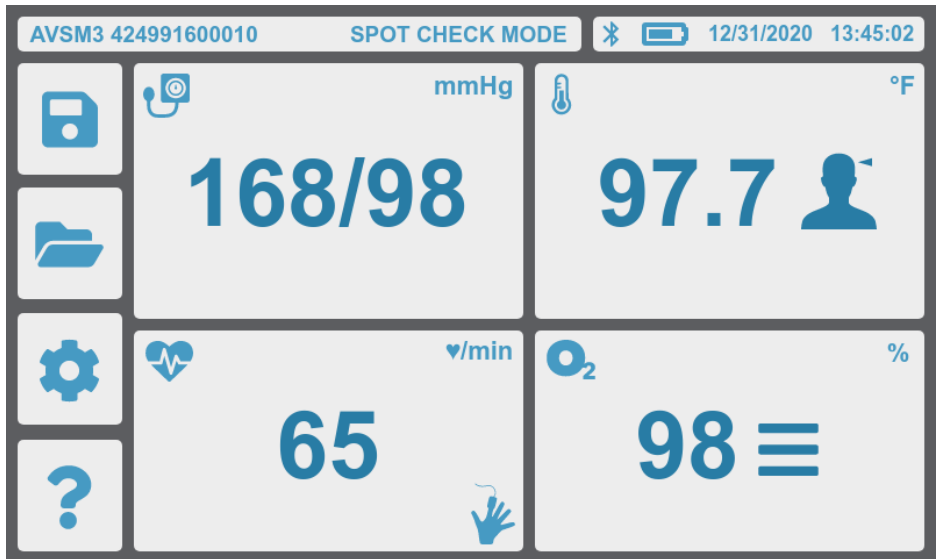

Figure 30. Home Screen (with 4 buttons)

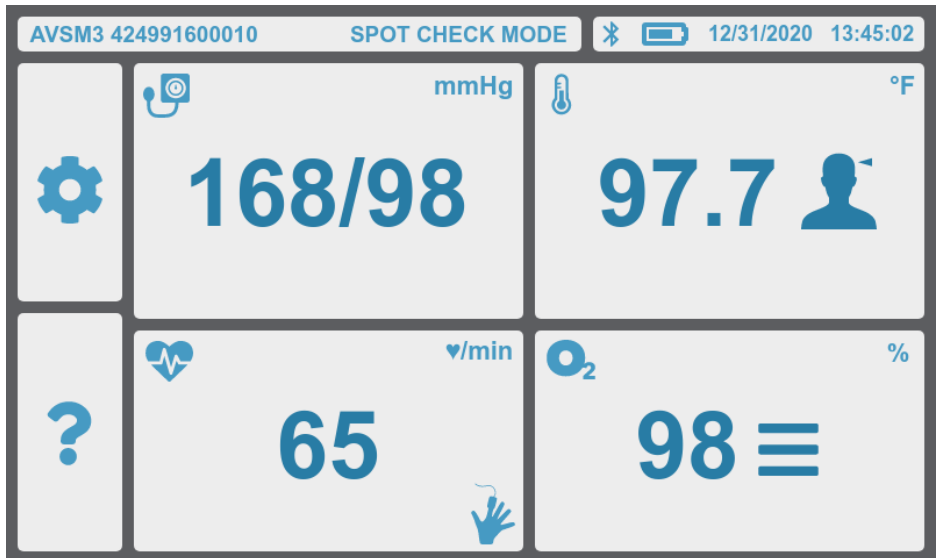

Figure 31. Home Screen (with 2 buttons)

NOTE: the default screen is spot check mode with 2 buttons.

Description of the Monitor *(cont.)*

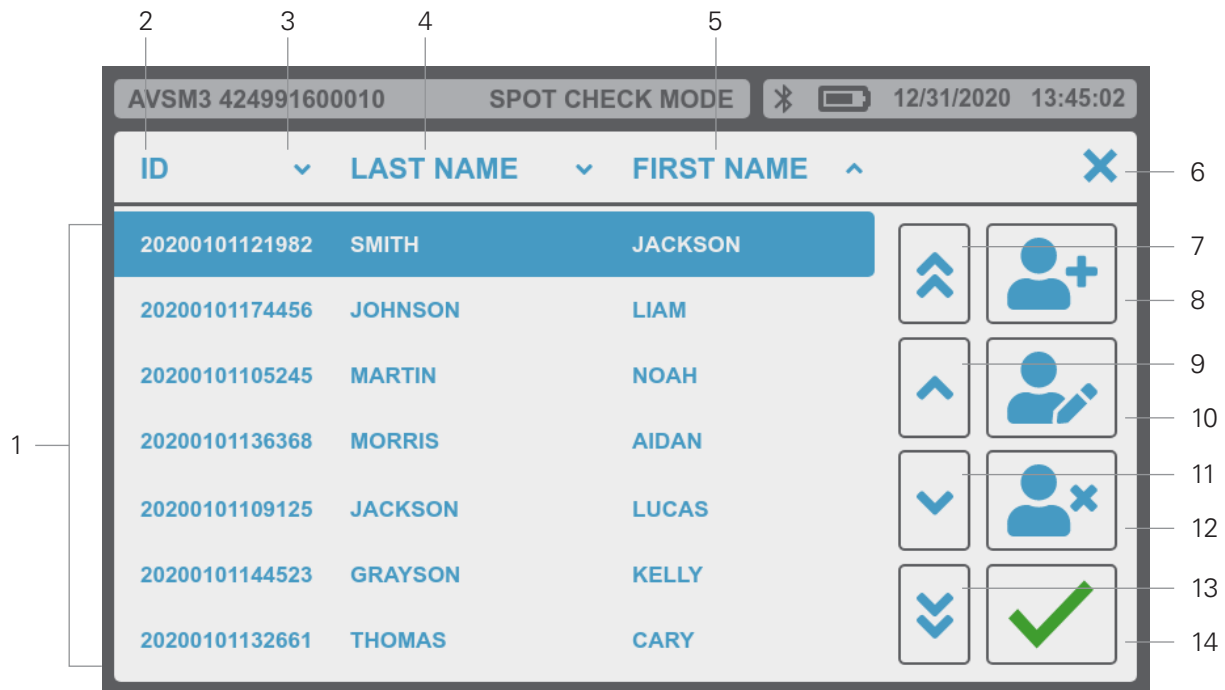

Figure 32. Resident List Screen

- | | |
|------------------------|----------------------------|
| 1 Resident List | 8 New Resident Button |
| 2 Resident ID | 9 Scroll Up Button |
| 3 Sort Icon | 10 Modify Button |
| 4 Resident Last Name | 11 Scroll Down Button |
| 5 Resident First Name | 12 Delete Button |
| 6 Close Button | 13 Scroll to Bottom Button |
| 7 Scroll to Top Button | 14 Select Resident Button |

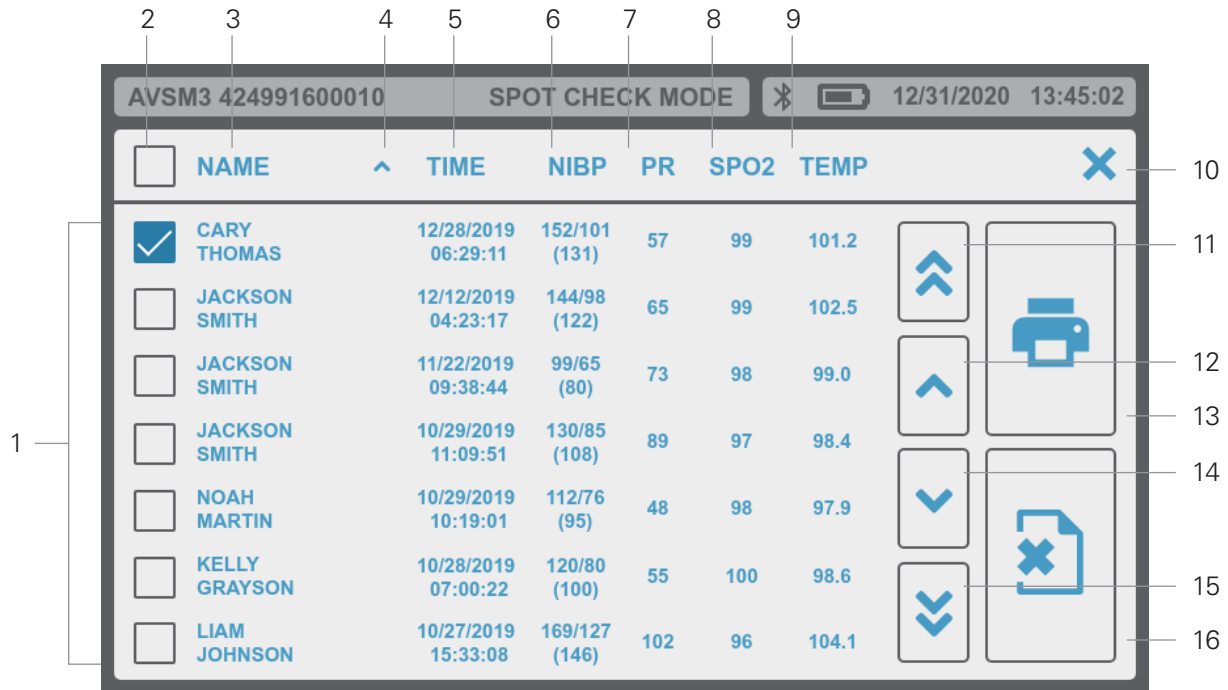

Figure 33. Locally Saved Readings Screen

- | | |
|--------------------------------------|----------------------------|
| 1 Select Checkbox | 9 Temp Measurement Value |
| 2 Select All Checkbox | 10 Close Button |
| 3 Resident Name | 11 Scroll to Top Button |
| 4 Sort Icon | 12 Scroll Up Button |
| 5 Time Stamp | 13 Print Button |
| 6 NIBP Measurement Value | 14 Scroll Down Button |
| 7 PR Measurement Value | 15 Scroll to Bottom Button |
| 8 SpO ₂ Measurement Value | 16 Delete Button |

Description of the Monitor *(cont.)*

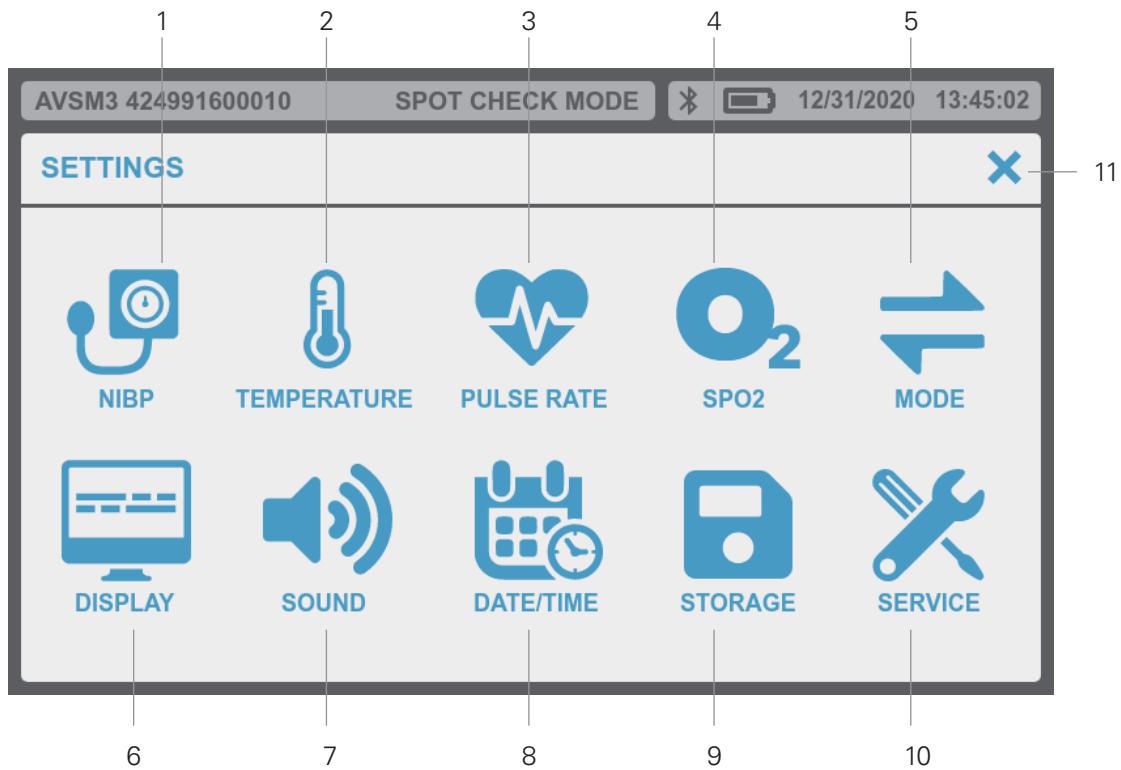

Figure 34. Settings Screen

- | | |
|--------------------|--------------------|
| 1 NIBP | 7 Sound |
| 2 Temperature | 8 Date/Time |
| 3 Pulse Rate | 9 Storage |
| 4 SpO ₂ | 10 Service Setting |
| 5 Mode | 11 Close Button |
| 6 Display | |

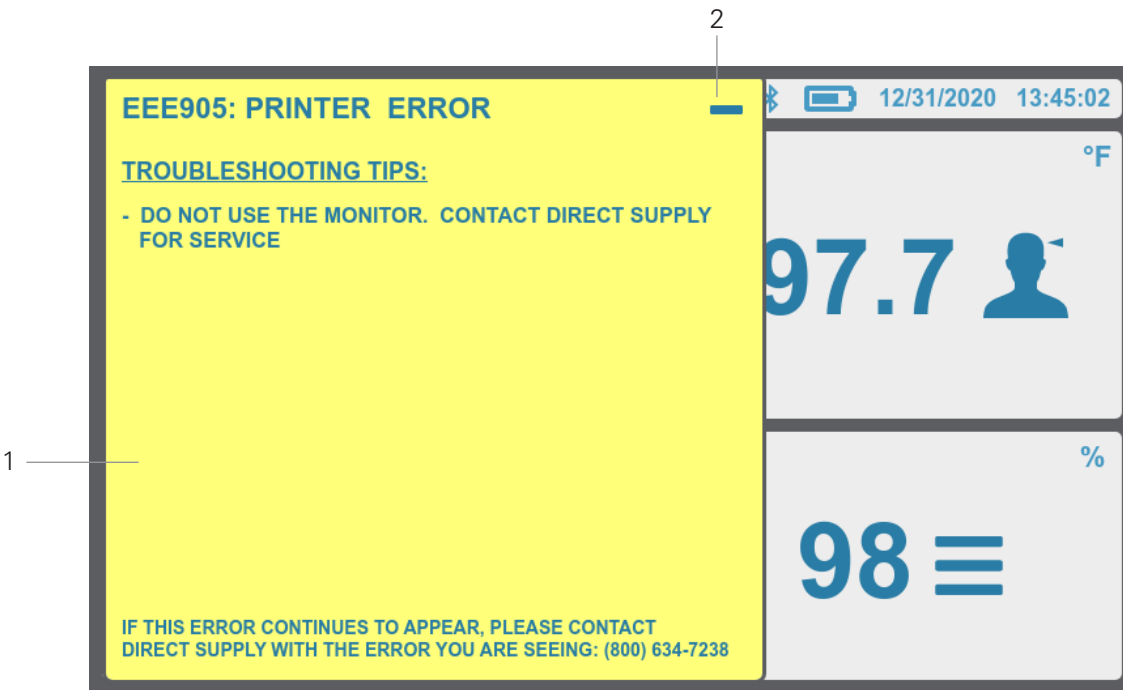















Figure 35. Alert Window

1 Alert Window

2 Minimize Alert Window

Description of the Monitor *(cont.)*

Display Icons

Symbols	Description	Symbols	Description
	NIBP Parameter		Audio Alarm Paused (Blinking Icon)
	NIBP Interval		Alarm Audio Off
mmHg	NIBP Unit: mmHg		SpO ₂ Parameter
kPa	NIBP Unit: kPa	%	SpO ₂ Unit
	PR Parameter		Resident List Icon
♥/min	PR Unit		Save Icon
	Pulse Rate Source : NIBP		Locally Saved Readings Icon
	Pulse Rate Source : SpO ₂		Settings Icon
	Temp Parameter		Help Icon
°F	Temperature in degrees Fahrenheit		Battery Full Icon
°C	Temperature in degrees Celsius		Battery Three Quarters Icon
	Temp Mode : Continuous		Battery Half Icon
	Temp Mode : Fast Predict		Battery Quarter Icon
	Temp Mode : Cold Predict		Battery Low Icon
blank	Temp Mode : Predict		Battery Critically Low Icon
	Bluetooth Icon		

Setting Up the Monitor

⚠ WARNING	To ensure accurate performance and prevent device failure, do not expose the monitor to extreme moisture, including direct exposure to rain. Such exposure may cause inaccurate performance or device failure. Refer to Specification section.
⚠ WARNING	The monitor should not be used adjacent to or stacked with other equipment. If adjacent or stacked use is necessary, the monitor should be observed to verify normal operation in the configuration it is to be used.
⚠ WARNING	Make sure that the monitor speaker is not obstructed. Failure to do so could result in an inaudible alarm tone.
⚠ CAUTION	Recharging the battery is strongly recommended when the battery has not been recharged for 2 or more months.
⚠ CAUTION	Follow local government ordinances and recycling instructions regarding disposal or recycling of device components, including battery.
⚠ CAUTION	If the case appears damaged, do not use the monitor and contact Direct Supply.

Unpacking and Inspection

The monitor is shipped in one carton. Examine the carton carefully for evidence of damage. Contact Direct Supply immediately if any damage is discovered. Refer to the **Maintenance** section for instructions on returning damaged items.

NOTE: Refer to the **Performance Verification** section in the service manual for detailed information.

Set the monitor so the user can easily see the screen. Normally it is recommended to set at a distance of 1 meter from the user, with the user within 60° of the center of the display.

If the buttons or touchscreen do not work, or produce incorrect function, contact Direct Supply.

List of Components

The following items are standard in the package.

Standard Accessories

Items	Qty	Items	Qty
AVSM3 SNF monitor	1	For Filac 3000 thermometer: Filac 3000 Oral Probe 1.2m	1
Owner's manual	1	Filac 3000 Oral Isolation Chamber	
AC power cord	1	Filac 3000 Probe Cover	
NIBP Connector Hose (1.2m)	1	<i>* Only when Filac 3000 thermometer option is installed</i>	
NIBP Cuff one piece durable cuff for Adult (18-29 cm)	1	Exergen thermometer	1
NIBP Cuff one piece durable cuff for Adult (28-40 cm)	1	<i>* Only when Exergen thermometer option is installed</i>	
For MD1 SpO ₂ module: SpO ₂ reusable sensor YM-1 SpO ₂ extension cable MEX03	1	ACTT-1 thermometer	1
<i>* Only when MD1 SpO₂ module option is installed</i>		<i>* Only when ACTT-1 thermometer is installed</i>	
For Nellcor SpO ₂ module: SpO ₂ reusable sensor DS100A SpO ₂ extension cable DOC-10	1	ACIT-1 thermometer	1
<i>* Only when Nellcor SpO₂ module option is installed</i>		<i>* Only when ACIT-1 thermometer is installed</i>	
		8-hour Li-ion battery	1

Optional items may be ordered if needed. Contact your local supplier for pricing and ordering information.

Setting Up the Monitor *(cont.)*

Optional Accessories

Items	Qty
Filac 3000 Oral Probe (2.7m) * Only when Filac 3000 thermometer option is installed	-
NIBP Cuff soft disposable cuff for Adult (18-29 cm)	-
NIBP Cuff soft disposable cuff for Adult (28-40 cm)	-
NIBP Cuff soft disposable cuff for Adult (40-55 cm)	-
NIBP Cuff one piece durable cuff for Adult (40-55 cm)	-
NIBP Connector Hose (3m)	-
Printer paper *Only when Printer option is installed.	5

Power Cable Connections

⚠ WARNING	Do not connect to an electrical outlet controlled by a wall switch because the monitor may be accidentally turned off.
⚠ CAUTION	If the integrity of the AC power source is in doubt, the monitor must be operated from its internal battery.

AC Power

Make sure that the AC outlet is properly grounded and supplies the specified voltage and frequency (100-240V~ 50-60 Hz).

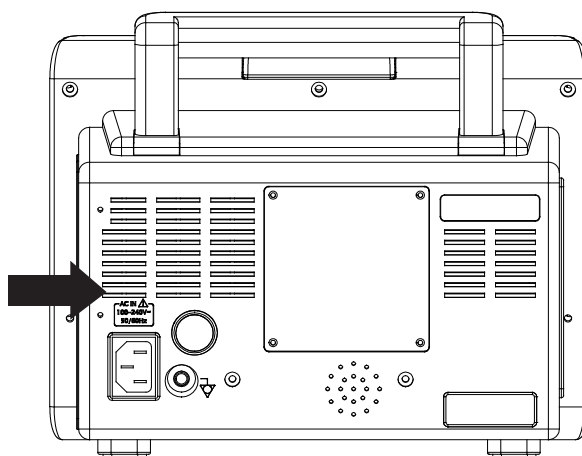

Figure 36. AC Power Connection

1. Connect the female connector end of the AC power cord to AC power connector on the monitor's rear panel.
2. Plug the male connector end of the AC power cord into a properly grounded outlet.
3. If necessary, connect grounding wire. Connect the grounding wire connector to the equipotential terminal on the rear panel. Now attach the clip end of the grounding wire to the medical equipment grounding terminal on the wall.
4. Verify that the Battery Charging Indicator on the monitor's front panel is lit (only when a battery pack is inserted).

NOTE: Even if the monitor is not turned on, the Battery Charging Indicator is lit when the AC power cord is connected into a mains outlet.

NOTE: If the Battery Charging Indicator is not lit, check:

- The power cord
- The AC power connector
- The power outlet
- No battery installed

If the Battery Charging Indicator still is not lit although no problem is found, contact Direct Supply.

Battery Operation

⚠ CAUTION	Recharging the battery is strongly recommended when it has not been fully recharged for 2 or more months.
⚠ CAUTION	When the voltage of the battery is very low, it is a possibility of not operating.
⚠ CAUTION	The battery may be depleted due to self-discharge for a long storage. Recharge the battery when the device is initially installed.

NOTE: It is recommended that the monitor remain connected to an AC power source when not in use. This will ensure a fully charged battery whenever it is needed.

NOTE: As the battery is used and recharged over a period of time, the amount of time between the onset of the low battery alarm and the monitor shut-off may become shorter. It is recommended for service personnel to check periodically or replace the internal battery if necessary.

Operating the Monitor on Battery Power

The monitor has an internal battery that can be used to power the monitor when an AC power source is not available. The Battery Status Indicator appears on the display when the monitor is on battery power.

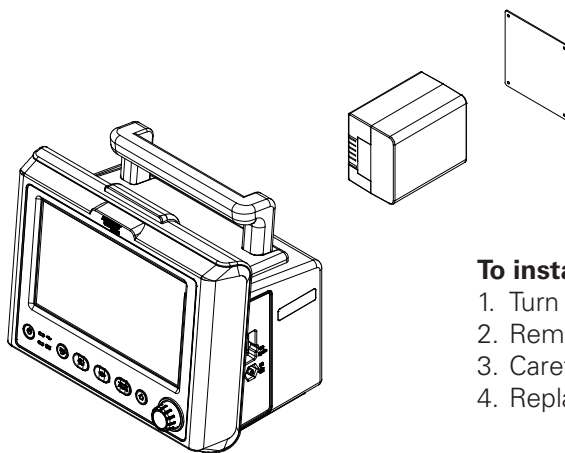

To install a battery pack:

1. Turn off the monitor.
2. Remove the battery cover using screwdriver.
3. Carefully insert the battery into the monitor.
4. Replace the battery cover and screws.

Figure 37. Battery Pack Installation

Setting Up the Monitor *(cont.)*

Front Panel Indications for Power Source

Power Connections	Front Panel Indications
AC power source	AC input icon and Charging icon appear in Power Status area. AC indicator and Battery indicator are lit.
Battery	Battery level percentage appears on Power Status area. Normal Battery icon appears on Power Status area.



A new, fully charged battery will provide 8 hours of operation under the following conditions:

- LCD Brightness set to default setting
- All monitoring parameters are active
- NIBP measurement once every 15 minutes
- No alarm audio
- No data output via Bluetooth
- No printing
- Ambient temperature at 25°C

Battery Status Indication

When operating on battery, the Battery Status Icon and battery level percentage in the upper right corner of the display indicates the battery condition.

The Monitor Battery Status Icon

Battery Status Icon	Battery Status Icon Color
	Blue (Normal)
	Blue (Low)
	Red (Critically Low)

NOTE: The Battery Status Icon is displayed in 6 levels depending on the amount of battery. Users can check the approximate amount of battery by the number of bars inside the Battery Status Icon.

NOTE: When the monitor is connected to an AC power source, the normal Battery Status Icons are displayed sequentially.

The Low Battery Status Icon will light when the remaining battery power is only enough for 15 minutes of operation.

This audible alarm cannot be paused while running on battery power. Connecting the monitor to AC power source will pause the alarm.

The Battery Status Indicator (critical low) will light red when remaining battery power is only enough for 5 minutes of operation. After that, the monitor will automatically shut down. Connect the monitor to an AC power source to avoid any loss of locally saved readings data or settings.

Charging a Low Battery

⚠ CAUTION The partial charge of a battery results in a shortened battery life.

1. Connect the monitor to AC power source to charge a low or depleted battery (see the **Setting up the Monitor** section).
2. Verify that the Battery Charging Indicator is yellow and lit.

Front Panel Indications for Battery Status

Charging status	Battery Charging Indicator
Full charged	Green
Charging	Yellow
Not installed	OFF

NOTE: Even if the monitor is turned off, the Battery Charging Indicator is lit while the battery is recharged.

NOTE: A full charge of a depleted battery takes over 12 hours per battery.

NOTE: The battery charging function may be blocked if the ambient temperature is above 35°C, or when the battery pack temperature is above 45°C

Measurement Cable Connections

⚠ WARNING

Use only accessories supplied intended for use with this monitor. Use accessories according to the manufacturer's directions for use and your facility's standards. Use only accessories that have passed the recommended biocompatibility testing in compliance with ISO10993-1.

NOTE: Both frequent checks by the operator on a daily basis and more comprehensive technical checks less frequently are covered by this requirement in order to detect mechanical damage and damage to cables, etc.

NIBP Hoses and Cuffs

1. Select an appropriate size cuff for the resident. (Refer to the **NIBP Monitoring** section.)
2. Connect the hose to the "NIBP" connector making sure to tighten the connector. (See Figure 15)
3. Attach the cuff to the end of the hose.

SpO₂ Cables and Sensors

1. Select an appropriate sensor for the resident and desired application. (Refer to the **SpO₂ Monitoring** section.)
2. Connect the extension cable to the "SpO₂" connector on the monitor's right panel. (See Figure 15)
3. Attach the sensor to the end of the cable.

Thermometer

1. Select the appropriate thermometer(s) for the desired application.
2. Attach the Probe Cover to the end of thermometer probe (optional). (Refer to the **Monitoring the Temperature** section for details.)

Setting Up the Monitor *(cont.)*

External Interface

The monitor provides external connectors to support communication with external equipment and functions such as a nurse call or PC and external display equipment connection. The monitor, with its optional built-in Bluetooth module, functionally performs the same as the monitor connected to the central system. The monitor with Bluetooth module can send and receive resident data through the central system.

⚠ WARNING	Any connections between this monitor and other devices must comply with applicable medical systems safety standards such as IEC 60601-1. Failure to do so could result in unsafe leakage and grounding conditions.
⚠ WARNING	The external interface function (wireless network and interface for communication) should not be used as the primary source of alarm notification. The audible alarms of the monitor, used in conjunction with clinical signs and symptoms, are the primary sources for notifying medical personnel that an alarm condition exists.

NOTE: *This equipment is to be used on a wireless network (Bluetooth) and the communication wirings (Nurse Call Interface (RJ11)) are limited to inside of the building.*

Cable Connection

⚠ CAUTION	The nurse call feature is not functional whenever the monitor alarms are paused.
⚠ CAUTION	The nurse call function needs to be tested after it has been set up in your facility. The nurse call feature should be tested whenever setting up the monitor in a location that uses nurse call. One way to test the nurse call function is to create an alarm condition (for example, sensor disconnect) and verify that your facility's nurse call system is activated.

Nurse Call Interface

The nurse call feature of the monitor is operational when the monitor is powered by AC power or battery power. The nurse call feature of the monitor works in conjunction with the nurse call system of your institution when the monitor sounds an audible alarm.

The monitor provides the nurse call interface of relay closure type. The interface functions when the monitor is operating either on AC power or battery power.

The remote location is signaled anytime there is an alarm audio. If the alarm audio has been turned off or paused, the nurse call function is also turned off.

Nurse Call Relays Normally Open/Closed

Pins 2 and 3 provide a relay that closes when an alarm is sounding on the monitor. Pins 1 and 2 provide a relay that opens when an alarm is sounding. Pin 2 is a common lead for both relays.

The pin layouts of Nurse Call interface are 6-pin. The pin layout and description of 6 pins are illustrated below.

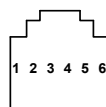

Figure 38. Nurse Call Interface Pin Layout

Nurse Call Interface Connections

Pin #	Signal
1	Nurse call normally close
2	Nurse call common lead
3	Nurse call normally open
4	Not connected
5	Not connected
6	Not connected

USB Interface

The USB A port is used to update the firmware of the monitor. The USB Mini port is used to transmit monitor data to a connected device.

Using the Monitor

⚠ WARNING	If the Power-On Self-Test (POST) is not completed successfully, do not use the monitor.
⚠ WARNING	Each time the monitor is used, check alarm limits to make sure that they are appropriate for the resident being monitored.
⚠ WARNING	If different alarm presets are used for the same or similar equipment in any single area, e.g. an intensive care unit or cardiac operating room, a potential hazard can exist.
⚠ WARNING	Keep residents under close surveillance when monitoring. It is possible, although unlikely, that radiated electromagnetic signals from sources external to the resident and the monitor can cause inaccurate measurement readings. Do not rely entirely on the monitor readings for resident assessment.
⚠ WARNING	Demo Mode is for demonstration purposes only. Do not use Demo Mode when a resident is attached to the monitor.
⚠ CAUTION	When power is turned on, the monitor automatically starts the Power-On Self-Test (POST), which tests the monitor circuitry and functions. During Power-On Self-Test (POST), confirm that the monitor display turns on. If the monitor display does not function properly, do not use the monitor. Instead, contact Direct Supply.
⚠ CAUTION	If the monitor is stored for long periods in an unused state, be sure to turn off the power.

NOTE: A tone sounds when the monitor completes the Power-On Self-Test (POST). This functions as an audible confirmation that the speaker is performing properly. If the speaker does not function, the alarm warning sounds cannot be heard.

NOTE: If the monitor screen and sound do not function properly, do not use the monitor. Please contact Direct Supply.

NOTE: When the power source is changed, the monitor makes an informative sound.

Power On/Off

Power On

1. Press and hold the **Power Button** for 1 second.
2. The alarm window will light for 1 second, and the Knob LED will light up while the monitor is on.
3. After the Power-On Self-Test (POST), the home screen will be displayed on the monitor.

NOTE: If the monitor detects an internal problem during Power-On Self-Test (POST), the monitor will sound an alarm and display a POST error pop up message. An error is recorded in the log. If an error code is displayed, contact qualified service personnel or your local supplier for assistance.

Power Off

When the monitor is on, press and hold the **Power Button** for 1 second to turn off the monitor.

NOTE: If the monitor is locked in an abnormal state, the monitor may be forcibly shut down by pressing and holding the **Power Button** for 15 seconds or more.

Home Screen

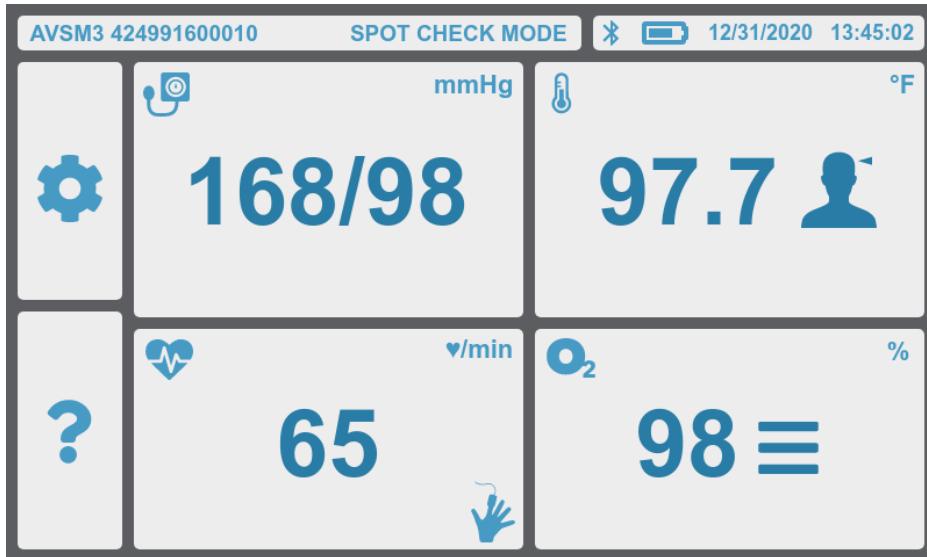

Figure 39. Home Screen

Resident List Button

Users can enter the resident list screen by pressing the **Resident List Button**.

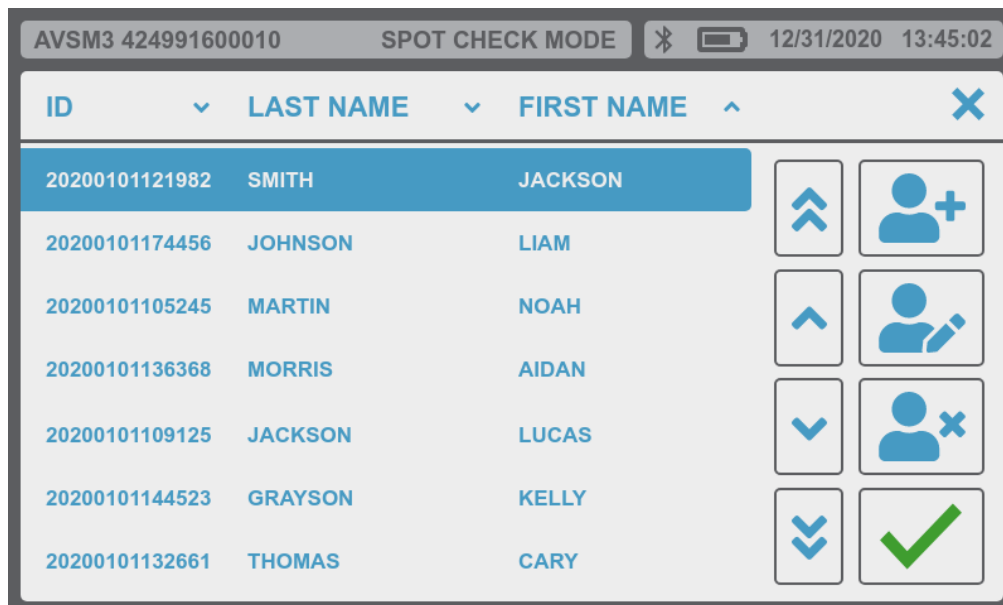

Figure 40. Resident List Screen

Using the Monitor *(cont.)*

Save Readings Button

Users can locally save the readings displayed on the monitor by pressing the **Save Readings Button**.

NOTE: The **Save Readings Button** is only available when the Data Storage node is set to 'RESIDENT' or 'ANONYMOUS'.

NOTE: After the **Save Readings Button** is pressed, the save function is disabled for 3 seconds.

Locally Saved Readings Button

NOTE: Do not connect more than one resident to the monitor. Do not connect more than one monitor to a resident.

NOTE: The locally saved readings can be sorted by Resident Name or Time by touching the sort icon next to the column heading.

NOTE: For more information about the Locally Saved Data, refer to **Saved Readings** section.

<input type="checkbox"/>	NAME	TIME	NIBP	PR	SPO2	TEMP		
<input checked="" type="checkbox"/>	CARY THOMAS	12/28/2019 06:29:11	152/101 (131)	57	99	101.2	↑	Print
<input type="checkbox"/>	JACKSON SMITH	12/12/2019 04:23:17	144/98 (122)	65	99	102.5	↑	
<input type="checkbox"/>	JACKSON SMITH	11/22/2019 09:38:44	99/65 (80)	73	98	99.0	↑	Print
<input type="checkbox"/>	JACKSON SMITH	10/29/2019 11:09:51	130/85 (108)	89	97	98.4	↓	
<input type="checkbox"/>	NOAH MARTIN	10/29/2019 10:19:01	112/76 (95)	48	98	97.9	↓	Delete
<input type="checkbox"/>	KELLY GRAYSON	10/28/2019 07:00:22	120/80 (100)	55	100	98.6	↓	
<input type="checkbox"/>	LIAM JOHNSON	10/27/2019 15:33:08	169/127 (146)	102	96	104.1	↓	

Figure 41. Locally Saved Readings Screen

Settings Button

Pressing the Settings Button takes the user to the Settings Screen. In the Settings Screen, users can check or change the NIBP, Temperature, Pulse Rate, SpO₂, Mode, Display, Sound, Date/Time, Storage and Service settings.

In each of the settings submenus, the header indicates which submenu the user is in, and below that header, the settings that the user can change. To exit the submenu, touch the close button in the upper right corner of the submenu window.

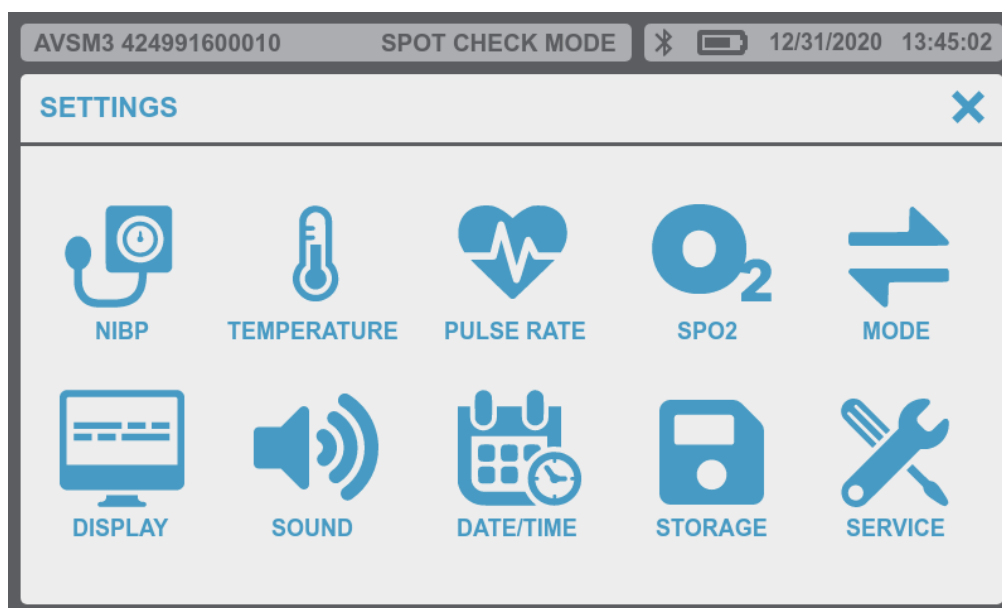

Figure 42. Settings Screen

NIBP

In the NIBP Menu, users may set Initial Inflation Pressure, NIBP Units, MAP Display, NIBP Interval and NIBP Alarms. For more information refer to **Monitoring NIBP** section.

NIBP Menu

Setting	Values/Submenu
Initial Inflation Pressure	Auto, 120 mmHg, 140 mmHg, 160 mmHg, 180 mmHg, 200 mmHg, 220 mmHg, 240 mmHg, 260 mmHg, 280 mmHg
NIBP Units	mmHg, kPa
MAP Display	On, Off
NIBP Interval*	Off, 1 min, 2 min, 2.5 min, 5 min, 10 min, 15 min, 30 min, 60 min, 120 min
NIBP Alarms*	(Open alarm limits submenu)

NOTE: The settings followed by an asterisk (*) are only available in Continuous mode.

Temperature

In the Temperature Menu, users may set Measurement Mode, Measurement Site, Temperature Units, and Temperature Alarms. For more information refer to **Monitoring the Temperature** section.

Temperature Menu

Setting	Values/Submenu
Measurement Mode	Predict, Fast Predict, Cold Predict, Continuous (for Filac 3000 temperature option only)
Measurement Site	Oral, Axillary (for Filac 3000 temperature option only)
Temperature Units	°F, °C
Temperature Alarms*	(Open alarm limits submenu)

NOTE: The setting followed by an asterisk (*) is only available in Continuous mode.

Using the Monitor *(cont.)*

Pulse Rate

In the Pulse Rate Menu, users may set Pulse Rate Source and Pulse Rate Alarms.

Pulse Rate Menu

Setting	Values/Submenu
Pulse Rate Source	Auto, NIBP, SpO ₂
Pulse Rate Alarms*	(Open alarm limits menu)

NOTE: The setting followed by an asterisk (*) is only displayed in Continuous mode.

SpO₂

In the SpO₂ Menu, users may set SpO₂ View, Sweep Speed, and SpO₂ Alarms. For more information refer to **Monitoring SpO₂** section.

SpO₂ Menu

Setting	Values/Submenu
SpO ₂ View	Pulse Amplitude, Waveform
Sweep Speed	12.5 mm/s, 25.0 mm/s
SpO ₂ Alarms*	(Open alarm limits menu)

NOTE: The setting followed by an asterisk (*) is only displayed in Continuous mode.

Mode

In the Mode Menu, users may set Operating Mode. For more information refer to the **Spot Check & Continuous Mode** section.

Mode Menu

Setting	Values
Operating Mode	Spot Check, Continuous

Display

In the Display Menu, users may set Brightness, Menu Timeout, Sleep Mode.

Display Menu

Setting	Values
Brightness	1, 2, 3, 4, 5
Menu Timeout	Off, 10 sec, 20 sec, 30 sec, 40 sec
Sleep Mode	Off, 5 min, 10 min, 20 min, 30 min

Brightness

Adjust the brightness of display.

Menu Timeout

The monitor will return to the home screen after the Menu Timeout period has elapsed.

Sleep Mode

If Sleep Mode is enabled, the monitor will shut off the display if no user input is received over the current Sleep Mode setting. If the user touches the screen, the monitor received input, or a new alarm condition is activated, the display turns back on.

Sound

In the Sound Menu, users may set: Key Beep Volume, Pulse Tone Volume, Other Sound Volume, Completion Sound, and Alarm Volume.

Sound Menu

Setting	Value
Key Beep Volume	Off, 1, 2, 3, 4, 5
Pulse Tone Volume	Off, 1, 2, 3, 4, 5
Other Sound Volume	Off, 1, 2, 3, 4, 5
Completion Sound	On, Off
Alarm Volume	1, 2, 3, 4, 5

Key Beep Volume

Sets the Key Beep volume generated by the monitor.

Pulse Tone Volume

Sets Pulse Tone volume generated by the monitor.

Other Sound Volume

Sets the Other Sounds volume generated by the monitor.

Completion Sound

Activates/deactivates the NIBP/Temp measurement completion sound.

Alarm Volume

Sets the Alarm Volume generated by the monitor.

Date/Time

In the Date/Time Menu, users may set the date and time displayed on the monitor display and printed out a printer paper.

Using the Monitor *(cont.)*

Date/Time Menu

Setting	Value
Month	1 ~ 12
Day	1 ~ 28 / 1 ~ 29 / 1 ~ 30 / 1 ~ 31
Year	2020 ~ 2035
Hour	0 ~ 23
Minute	0 ~ 59

NOTE: If the setting value is out of range, the monitor will beep.

NOTE: Press the close button to set Date/Time.

Storage

In the Storage Menu, users may set Data Storage and Auto Delete After settings. For more information refer to **Saved Readings** section.

Storage Menu

Setting	Value
Data Storage	Off, Anonymous, Resident
Auto Delete After	1 Day, 1 Week, 1 Month, 1 Year, Never

Service

To access the Service Menus, users need to enter the Pass Code.

NOTE: For more details about entering the Pass Code and accessing the Service Menus, contact Direct Supply.

Service Menu

Setting	Submenu
Pass Code	(Enter Pass Code to open the Service menu)

Pass Code

When the numeric keypad appears on the display, enter the Pass Code to access the Service Menus. For more details on entering the Pass Code, refer to the **Service Manual**.

QWERTY Keyboard and Numeric Keypad

The monitor supports two types of user data entry – QWERTY Keyboard and Numeric Keypad. The appropriate data entry method will automatically popup when user input is needed.



Figure 43. QWERTY Keyboard

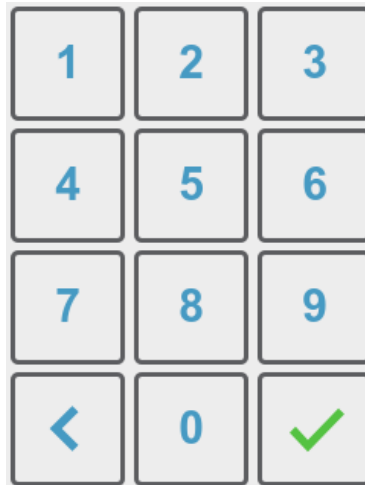

Figure 44. Numeric Keypad

Using the Monitor *(cont.)*

Help Button

Pressing the Help Button accesses the Help Menu. The Help Menu provides troubleshooting tips for each of the vitals modules installed, a description of all of the icons used in the user interface, and additional information on the manufacturing and usage data for the monitor.

Close Button: Returns the user to the Home Screen

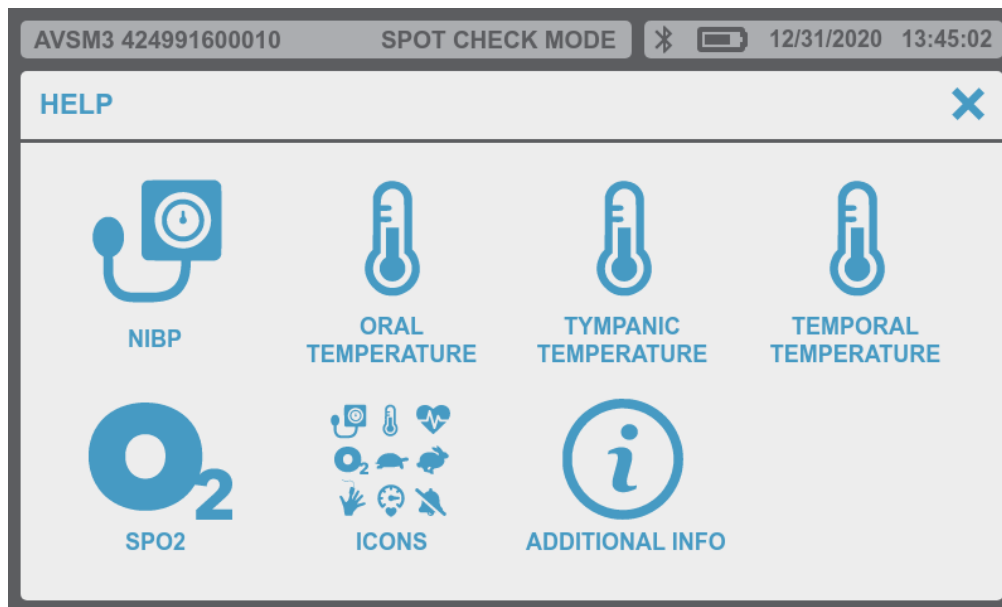

Figure 45. Help Screen

Spot Check Mode & Continuous Mode

General

The monitor offers two modes of operation: Spot Check Mode and Continuous Mode.

The operation and function of the monitor differ based on which mode it is in. Check the resident condition and intended use prior to selecting the mode of operation.

Spot Check Mode

Spot Check Mode is used to obtain a single set of resident vital signs at a specific point in time. Vitals-based alarms are disabled in Spot Check Mode.

Continuous Mode

Continuous Mode is used to collect multiple sets of resident vital signs over a period of time. Vitals-based alarms are enabled in Continuous Mode.

NOTE: In this manual, the operation of the monitor describes Spot Check Mode. The contents of the Continuous Mode is separately described.

NOTE: For more information, refer to **Description of the Monitor** section.

Changing the Operation Mode

This setting allows users to change the mode of operation. When the operation mode is changed, any existing measurement data is cleared from the Home Screen, any ongoing measurement is cancelled, and if Data Storage is set to RESIDENT, the resident is deselected.

NOTE: Before changing the Operation Mode, save the measurement data. Any data that is not saved prior to changing the Operation Mode will be lost.

To change the Operation Mode:

1. Press the **Setting Button**.
2. Press the **Mode Menu**.
3. Select the desired mode by using the **Arrow Buttons**.
4. After selecting an Operation Mode, close the **Mode Menu**.
5. Set appropriate vitals parameter alarm thresholds
6. Select a resident from the resident list prior to taking new measurements.

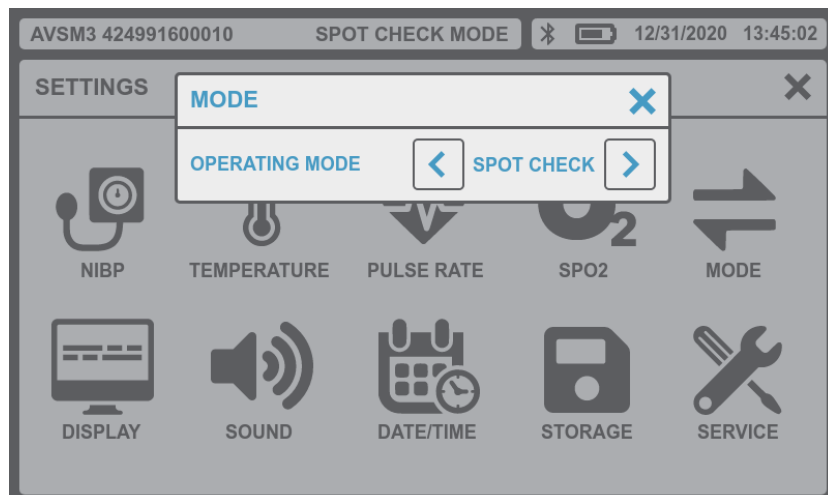

Figure 46. Mode Menu

Spot Check Mode & Continuous Mode *(cont.)*

Spot Check Mode

Spot Check Mode is used to obtain a single set of resident vital signs at a specific point in time, and only takes a few seconds.

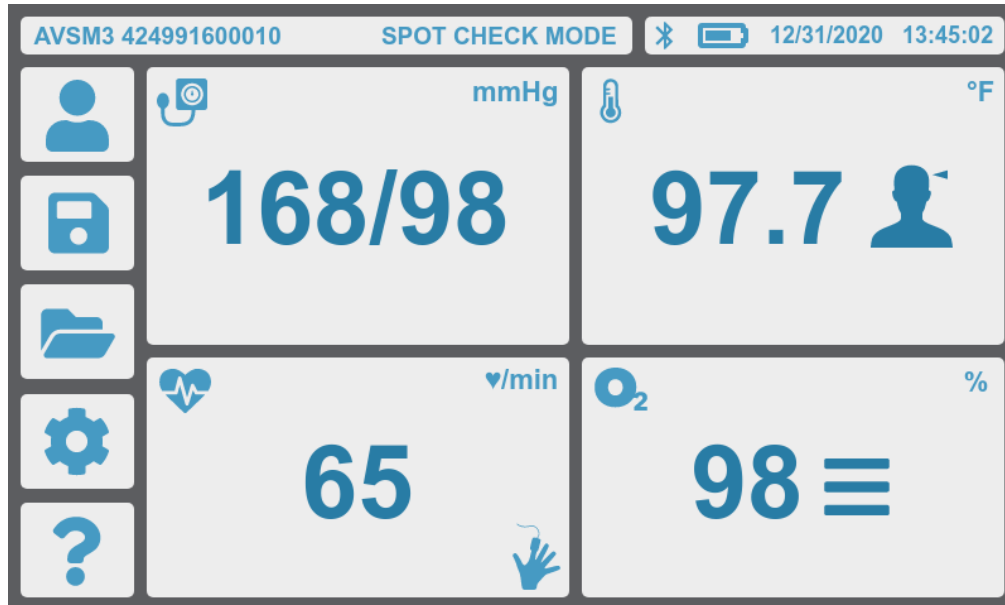

Figure 47. Home Screen in Spot Check Mode (with 5 buttons)

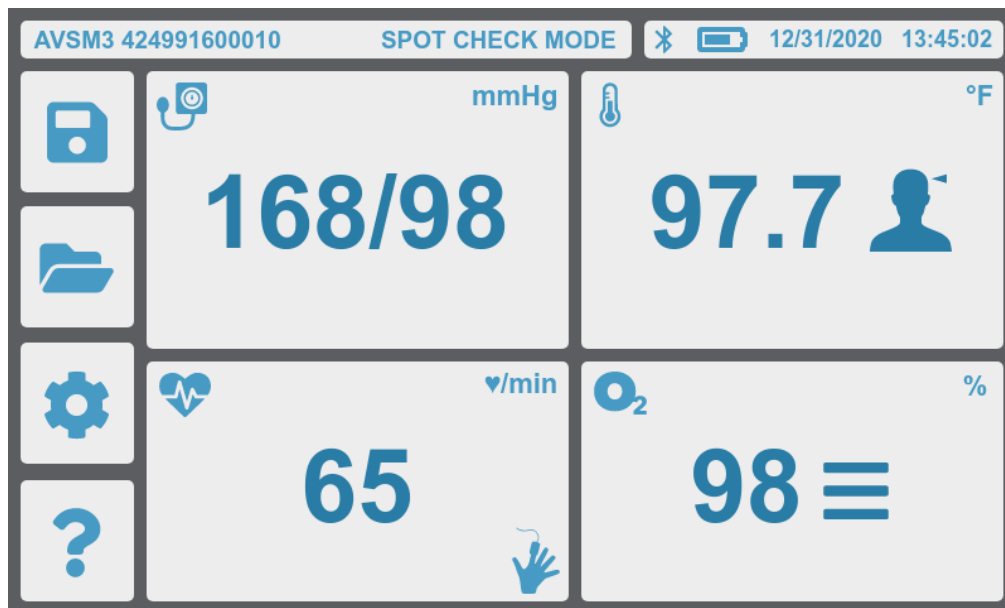

Figure 48. Home Screen in Spot Check Mode (with 4 buttons)

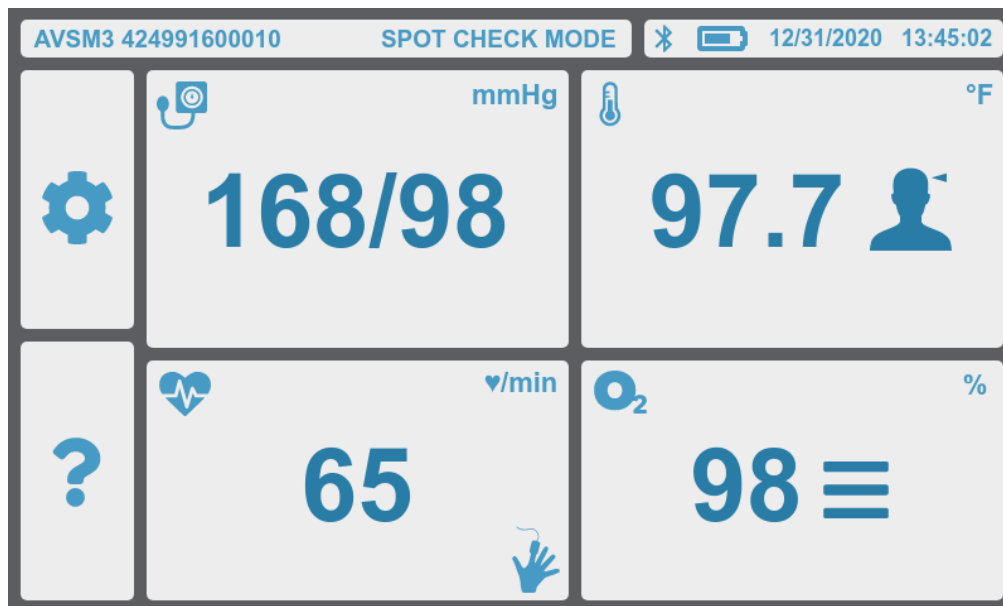

Figure 49. Home Screen in Spot Check Mode (with 2 buttons)

NOTE: The default screen is the Home Screen with 2 buttons.

Continuous Mode

Users can measure vital signs of resident more than twice at a specific interval, and can check the change in the resident condition during the interval.

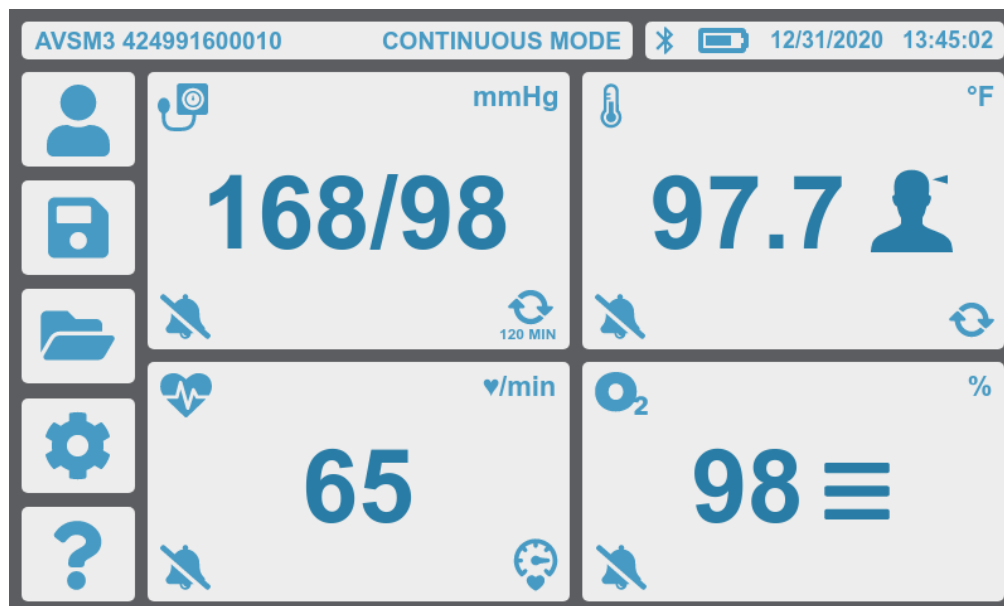

Figure 50. Home Screen in Continuous Mode (with 5 buttons)

Spot Check Mode & Continuous Mode *(cont.)*

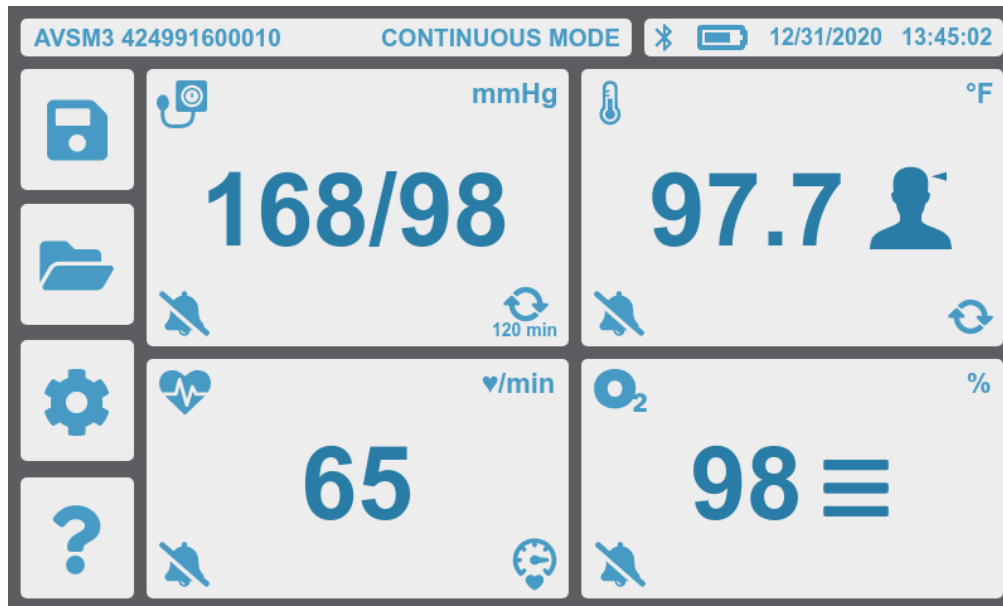

Figure 51. Home Screen in Continuous Mode (with 4 buttons)

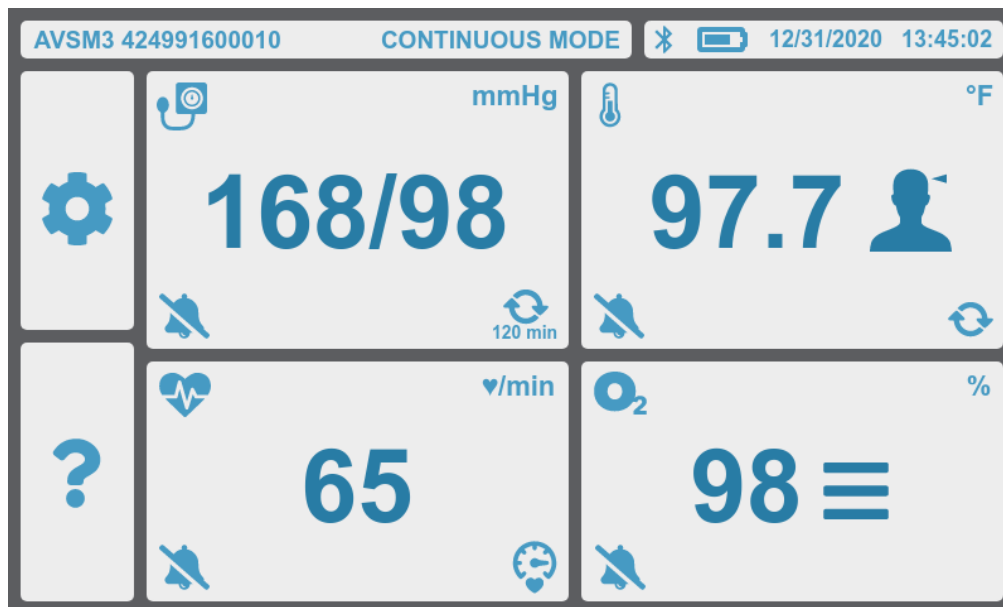

Figure 52. Home Screen in Continuous Mode (with 2 buttons)

Comparison between Spot Check Mode and Continuous Mode

This section indicates available operation or feature in Spot Check Mode and Continuous Mode. Users can check whether to use each function according to the operating mode.

Operation or Feature	Spot Check Mode	Continuous Mode	Reference
NIBP Interval Setting Button on front panel	Disabled	Enabled	Spot Check & Continuous Mode section
Set the NIBP Interval	Disabled	Enabled	Monitoring NIBP section
Save Readings Locally	Press the Save Button	<ul style="list-style-type: none"> • Press the Save Button • When any physiological alarm condition occurs • Upon completion of NIBP measurement or NIBP measurement failure 	Saved Readings section
Configure Alarms	Disabled	Enabled	Settings Button section
Operate the Exergen thermometer	Enabled	Disabled	Monitoring Temperature section
Operate the Filac 3000 thermometer	Enabled	Enabled	Monitoring Temperature section
Operate the ACTT-1 thermometer	Enabled	Disabled	Monitoring Temperature section
Operate the ACIT-1 thermometer	Enabled	Disabled	Monitoring Temperature section

Resident Management

General

The monitor can measure and store vital signs measurements, either anonymously or identified by resident. In the Resident List screen, users select a particular resident and take/store measurements for that resident. In addition, the user can add a new resident, modify a resident entry, or delete a resident.

Accessing the Resident List

To access the **Resident List Screen**, press the **Resident List Button**.

NOTE: The **Resident List Button** is not displayed on the Home Screen when Data Storage is set to 'ANONYMOUS'.

NOTE: The **Resident List Button**, **Save Button** and **Locally Saved Readings Button** are not displayed when the Data Storage is set to 'OFF'.

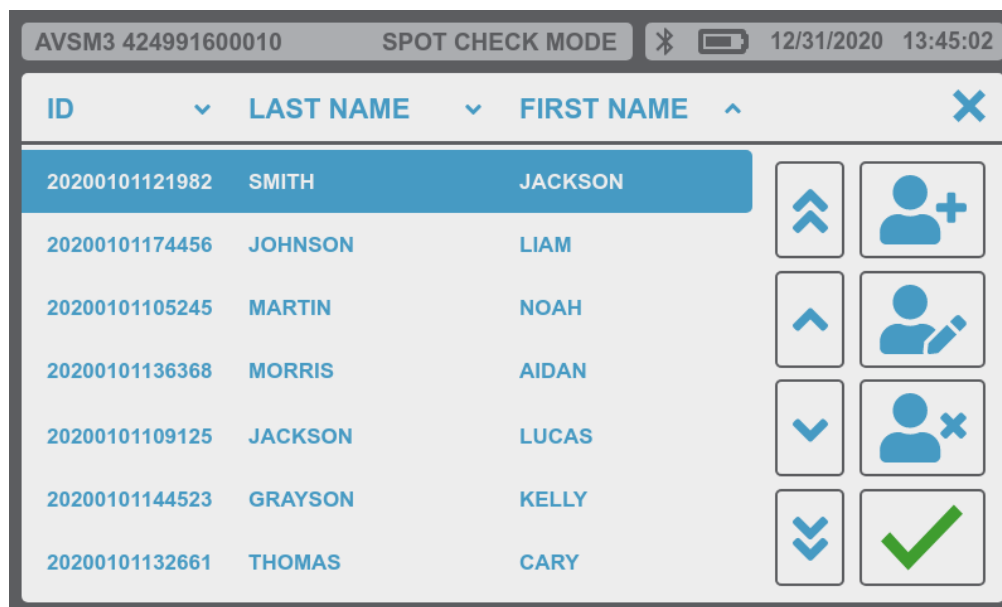

ID	LAST NAME	FIRST NAME		
20200101121982	SMITH	JACKSON	↑	Person +
20200101174456	JOHNSON	LIAM	↑	Person edit
20200101105245	MARTIN	NOAH	↓	Person x
20200101136368	MORRIS	AIDAN	↓	Checkmark
20200101109125	JACKSON	LUCAS	↓	
20200101144523	GRAYSON	KELLY	↓	
20200101132661	THOMAS	CARY	↓	

Figure 53. Resident List Screen

Resident List Screen Options

On the Resident List screen, users can add, delete, or modify a resident from the list. The resident list indicates the ID, Last Name and First Name of resident.

NOTE: After setting a resident's information, the measurement value is saved together with the resident information. User can search by using the resident information via **Locally Saved Readings Button**.

Add a new resident to the resident list

To add the new resident, press the **New Resident Button**. Users can enter the resident ID, resident Last Name, and resident First Name in the resident information window.

Press the **Enter Button** (green checkmark) to save the entered resident information, or press the **Close Button** to exit the window without saving the resident information.

NOTE: The QWERTY Keyboard will activate in each resident information window to enable users to enter the information.

Delete a resident from the resident list

In the Resident List screen, select the resident to delete, and press the **Delete Button**. A window will pop up and prompt the user to confirm the deletion of the resident.

Modify the resident information on the resident list

To modify the resident information, select the resident to modify and press the **Modify Resident Button**. The monitor displays the resident information window. Users can either check the selected resident information or update it. After modifying the resident information, press the **Enter Button** (green checkmark) to confirm the change.

Monitoring NIBP

⚠ WARNING	For best product performance and measurement accuracy, use only accessories intended for use with this monitor. Use accessories according to the manufacturer's directions for use and your facility's standards.
⚠ WARNING	Inaccurate measurements may be caused by incorrect cuff application or use. This can include placing the cuff too loosely on the resident, using the incorrect cuff size, or not placing the cuff at the same level as the heart, leaky cuff or hose, or excessive resident motion.
⚠ WARNING	In some cases, rapid, prolonged cycling of an oscillometric, noninvasive blood pressure monitor cuff has been associated with any or all of the following: ischemia, purpura, or neuropathy. Periodically observe the resident's limb to make sure that the circulation is not impaired for a prolonged period of time. Also make sure the cuff is placed according to directions in this manual and the cuff directions for use.
⚠ WARNING	Do not place the cuff, the catheter or SpO ₂ sensor on an extremity being used for intravenous infusion or any area where circulation is compromised or has the potential to be compromised.
⚠ WARNING	As with all automatically inflatable blood pressure devices, continual cuff measurements can cause injury to the resident being monitored. Weigh the advantages of frequent measurement and/or use of STAT mode against the risk of injury.
⚠ WARNING	Ensure the resident is quiet with minimal movement during NIBP readings; minimize the resident's shivering.
⚠ WARNING	Never place the cuff on an extremity being used for intravenous infusion or any area where circulation is compromised or has the potential to be compromised. Never fit NIBP system with Luer Lock adapters.
⚠ WARNING	Never use an adult monitor setting or cuff for an NIBP measurement on a neonatal patient. Adult inflation limits can be excessive for neonatal patients, even if a neonatal cuff is used.
⚠ WARNING	Too frequent measurements can cause injury to the resident due to blood flow interference.
⚠ WARNING	The cuff should not be applied over a wound as this can cause further injury.
⚠ WARNING	The cuff should not be placed on the arm on the side of a mastectomy. In the case of a double mastectomy use the side of the least dominant arm.
⚠ WARNING	Pressurization of the cuff can temporarily cause loss of function if simultaneously used with monitoring equipment on the same limb.
⚠ WARNING	Do not attach the cuff to a limb being used for IV infusions or any other intravascular access, therapy or an arterio-venous (A-V) shunt. The cuff inflation can temporarily block blood flow, potentially causing harm to the resident.
⚠ WARNING	Any blood pressure reading can be affected by the measurement site, the position of the resident, exercise, or the resident's physiologic condition. Environmental or operational factors which can affect the performance of the monitor and/or its blood pressure reading are common arrhythmias such as atrial or ventricular premature beats or atrial fibrillation, arterial sclerosis, poor perfusion, diabetes, age, pregnancy, pre-eclampsia, renal diseases, resident motion, trembling and shivering.
⚠ WARNING	Ignore the SpO ₂ alarm generated during NIBP measurement because the SpO ₂ measurement values might be inaccurate temporarily during the NIBP measurement.

⚠ CAUTION	In the automatic mode, the monitor displays results of the last blood pressure measurement until another measurement starts. If a resident's condition changes during the time interval between measurements, the monitor will not detect the change or indicate an alarm condition.
⚠ CAUTION	Any excessive resident motion may cause inaccurate measurements of non-invasive blood pressure. Minimize motion to improve blood pressure measurements.
⚠ CAUTION	Do not apply the blood pressure cuff to the same extremity as the one to which the SpO ₂ sensor is attached. Cuff inflation can disrupt SpO ₂ monitoring and lead to nuisance alarms.
⚠ CAUTION	Make sure that heavy objects are not placed on the cuff hose. Avoid crimping or undue bending, twisting, or entanglement of the hose.
⚠ CAUTION	A compressed or kinked connection hose may cause continuous cuff pressure resulting in blood flow interference and potentially harmful injury to the resident.

NOTE: Blood pressure measurements can be affected by the position of the resident, the resident's physiological condition and other factors.

NOTE: Blood pressure measurements determined with the monitor are equivalent to those obtained by a trained observer using the cuff/stethoscope auscultatory method, within the limits prescribed by the American National Standard for manual, electronic and automated sphygmomanometers.

NOTE: The user should check that the monitor is functioning while measurements are being made and check display periodically.

NOTE: Verify that the display updates after taking a measurement before accepting the displayed data as a current measurement.

NOTE: Check the cuff/hose connection and do not use the damaged cuff/hose. Follow the manufacturer's directions for use.

Setup Connections

When performing the NIBP measurements, including hypertension blood pressure measurements, it is important to follow suitable procedures to ensure valid, accurate results. Follow these procedures:

NOTE: 5 minutes should elapse before the first reading is taken.

1. Measure the resident's limb and select a proper size cuff. As a general rule, cuff width should span approximately two-thirds of the distance between the resident's elbow and shoulder.
2. Connect the cuff hose to the connector on the monitor's right panel. (See Figure 15).
3. Connect a cuff to the cuff hose and turn the connector to right to lock the hoses together. Firm connection must be made.
4. Resident should be seated comfortably with back and arms supported.
5. Resident should have their legs uncrossed, feet flat on the floor. The resident should not talk during the BP measurement.
6. Wrap the cuff around a bare arm or around an arm covered in thin clothing. Thick clothing or a rolled up sleeve will cause a major discrepancy in the blood pressure reading.
7. Wrap the cuff around the resident's arm so that the center of the cuff's rubber bladder sits on the artery of the upper arm. The hose should be brought out from the peripheral side without bending (the Brachial artery is located on the inside of the resident's upper arm.) At this time, check that the index line on the edge of the cuff sits inside the range. Use a different sized cuff if the index line is outside of the range because this will cause a major discrepancy in blood pressure reading.

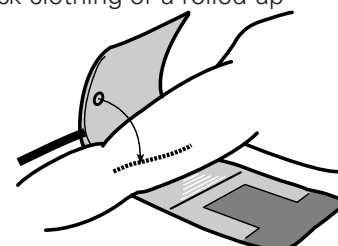
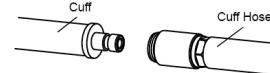

Monitoring NIBP *(cont.)*

⚠ CAUTION

The adult cuff should be wrapped around the arm tightly enough so that only two fingers can be inserted under it, above and below the cuff.

8. Maintain the height of the cuff-wrapped upper arm artery to that of the heart's right ventricle during measurement.
9. Follow the cuff directions for use when applying the cuff to the arm.

NOTE: *Obtaining NIBP readings can be more difficult in residents with arrhythmias. These arrhythmias increase the beat-to-beat pressure fluctuations, which increases the variability of the NIBP readings. Temporarily verify pressure using another method if it becomes difficult to obtain readings in the presence of arrhythmias.*

Cuff Size

Model Number	Arm Circumference (cm)	Subject
Soft Disposable Cuff	18.0 to 29.0	Adult
	28.0 to 40.0	
	40.0 to 55.0	
One Piece Durable Cuff	18.0 to 29.0	
	28.0 to 40.0	
	40.0 to 55.0	

Description of NIBP Operation

The NIBP tile displays Systolic, Diastolic, and Mean Arterial Pressure measurements. The NIBP tile also displays NIBP alarm status and NIBP interval. The user can touch the NIBP tile to access NIBP-specific monitor settings.

NIBP Measurement



Figure 54. NIBP Tile

- | | | | |
|---|-----------------------|---|-----------------------|
| 1 | NIBP Parameter Label | 5 | MAP Measurement Value |
| 2 | SYS Measurement Value | 6 | NIBP Auto Interval |
| 3 | Alarm Audio Icon | 7 | DIA Measurement Value |
| 4 | NIBP Unit | | |

Starting/Stopping an NIBP Measurement

Press the **NIBP Start Button** to start the NIBP measurement. In Spot Check Mode, the user can only start NIBP measurements using the **NIBP Start Button**. In Continuous Mode, an NIBP measurement can be started if the NIBP auto measurement interval has been set. To stop an NIBP measurement in progress, press the **NIBP Start Button** again.

Interval

Press the **Interval Button** to set the NIBP auto measurement interval. The NIBP interval can be set to OFF, 1, 2, 2.5, 5, 10, 15, 30, 60, 120 min. The NIBP interval can also be set via the NIBP menu of the Settings screen.

Pulse Rate Measurement with NIBP

The Pulse Rate tile displays pulse rate measurements. The Pulse Rate tile also displays PR alarm status, and the source of the PR measurement. The user can touch the **Pulse Rate tile** to access PR-specific monitor settings.



Figure 55. Pulse Rate Tile

- | | | | |
|---|------------------------------|---|-------------------|
| 1 | Pulse Rate Parameter Label | 4 | Pulse Rate unit |
| 2 | Pulse Rate Measurement Value | 5 | Pulse Rate Source |
| 3 | Alarm Audio Icon | | |

NOTE: Check the Pulse Rate Source setting in the **Pulse Rate Menu**. If Pulse Rate Source is set to SpO₂, refer to the **Description of SpO₂ Operation** section.

Monitoring NIBP *(cont.)*

Principle of measurement

The monitor performs Non-Invasive Blood Pressure measurements using the oscillometric measuring technique. A motorized pump inflates the cuff to initially blocking the flow of blood in the extremity. Then, under monitor control, the pressure in the cuff is gradually reduced, while a pressure transducer detects air pressure and transmits a signal to the NIBP circuitry.

When the cuff pressure is still above systolic pressure, small pulses or oscillations in the cuff pressure begin to be sensed by the transducer. As the cuff continues to deflate, oscillation amplitude increases to a maximum and then decreases. When maximum oscillation amplitude occurs, the cuff pressure at that time is measured as mean arterial pressure (MAP). The systolic and diastolic pressures are calculated based on analysis of the oscillation amplitude profile.

Oscillometric Method

The blood pressure values are determined by measuring the small oscillations (changes) in the cuff pressure caused by the heart's contractions as the pressure in the cuff is released. AVSM3 SNF's measurement technology utilizes a unique deflation technique, Dynamic Linear Deflation. This cuff deflation technique allows the AVSM3 SNF monitor to measure each small change in the cuff pressure oscillations that directly correspond to the measurement's systolic, mean and diastolic blood pressure values.

The cuff is first increased in pressure until it reaches a pressure above arterial occlusion. As the cuff starts to deflate, the pulse rate of the resident is determined and the deflation speed of the cuff is modified to create a resident specific deflation speed. As the pressure decreases, small cuff pressure oscillations are recorded that correspond to the applied pressure of the blood under the cuff as the heart contracts. These oscillations increase in strength as the cuff pressure approaches the systolic blood pressure value. A sudden increase in oscillation amplitude indicates that the resident's systolic blood pressure is now able to push blood completely through beneath the cuff. The oscillation amplitude continues to increase as the pressure in the cuff is decreases until the mean blood pressure value is reached. The oscillation strength then starts to diminish and finally drop off as the diastolic blood pressure value is reached.

The oscillometric method does not determine an instantaneous blood pressure reading like the auscultatory method employing a microphone-type auto blood pressure monitor but, as described above, determines blood pressure from an uninterrupted changing curve, which means that the oscillometric method is not easily effected by external noise and electrosurgical instruments.

NOTE: *This equipment is suitable for use in the presence of electro-surgery.*

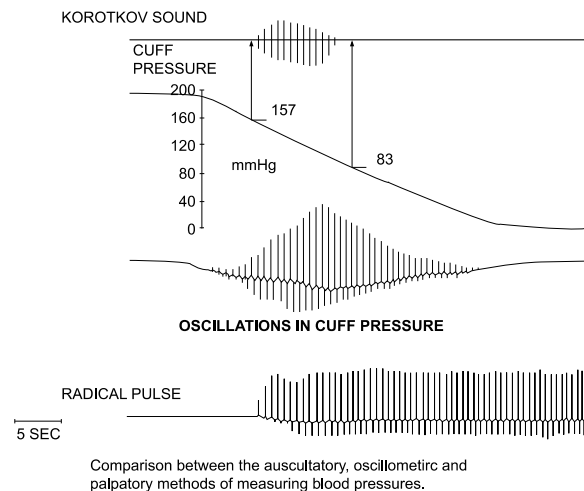

Monitoring SpO₂

⚠ WARNING	Use only accessories intended for use with this monitor. Use accessories according to the manufacturer's directions for use and your facility's standards.
⚠ WARNING	Tissue damage can be caused by incorrect application or use of an SpO ₂ sensor. Harm can be caused, for example, by wrapping the sensor too tightly, by applying supplemental tape, or by leaving a sensor on too long in one place. Inspect the sensor site as directed in the sensor directions for use to ensure skin integrity, correct positioning and adhesion of the sensor.
⚠ WARNING	Do not use damaged SpO ₂ sensors. Do not use the SpO ₂ sensor with exposed optical components. Do not immerse sensor completely in water, solvents, or cleaning solutions because the sensor and connectors are not waterproof. Do not sterilize SpO ₂ sensors by irradiation, steam or ethylene oxide. Refer to the cleaning instructions in the directions for use for reusable SpO ₂ sensors.
⚠ WARNING	<p>Inaccurate measurements may be caused by:</p> <ul style="list-style-type: none"> • incorrect sensor application or use • significant levels of dysfunctional hemoglobin (such as carboxyhemoglobin or methemoglobin) • intravascular dyes such as indocyanine green or methylene blue • exposure to excessive illumination, such as surgical lamps (especially ones with a xenon light source), bilirubin lamps, fluorescent lights, infrared heating lamps, or direct sunlight • excessive resident movement • high-frequency electrosurgical interference and defibrillators • venous pulsations • placement of a sensor on an extremity with a blood pressure cuff, arterial catheter, or intravascular line • resident conditions such as hypotension, severe vasoconstriction, severe anemia, hypothermia, cardiac arrest, or shock • arterial occlusion proximal to the sensor • unspecified environmental conditions • unspecified length of the extension cable
⚠ WARNING	Do not attach any cable to the sensor port connector that is intended for computer use.
⚠ WARNING	Use only pulse oximetry sensors and pulse oximetry cables intended for use with this monitor when connecting to the sensor connector. Connecting any other cable or sensor influences the accuracy of the sensor data, which may lead to adverse results.
⚠ WARNING	Misapplied sensors with excessive pressure for prolonged periods may damage the resident.
⚠ WARNING	Do not use any other cables to extend the length of the approved interface cable. Increasing the length will degrade signal quality and may lead to inaccurate measurements.
⚠ CAUTION	The sensor disconnect error code and associated alarm indicate the sensor is either disconnected or the wiring is faulty. Check the sensor connection and, if necessary, replace the sensor, extension cable or both.
⚠ CAUTION	Reusable sensors may be used on the same site for a maximum of 4 hours, provided the site is inspected routinely to ensure skin integrity and correct positioning.

Monitoring SpO₂ (cont.)

Refer to the notice below if the Nellcor SpO₂ module is installed.

NOTE: Purchase of this instrument confers no express or implied license under any Nellcor patent to use the instrument with any sensor that is not manufactured or licensed by Nellcor.

NOTE: The user should check that the monitor is functioning while measurements are being made and check the display periodically.

NOTE: Verify that the display updates after taking a measurement before accepting the displayed data as a current measurement.

Setup Connections

When selecting a sensor, consider the resident's weight and activity, adequacy of perfusion, availability of sensor sites, need for sterility and anticipated duration of monitoring. Contact Direct Supply for ordering information.

1. Select the proper sensor for the resident.
2. Connect the extension cable to the SpO₂ connector on the monitor's right panel and lock it (See Figure 15).
3. Connect the sensor to the extension cable and lock it.
4. Carefully apply the sensor to the resident, as described in the sensor directions for use. Observe all warnings and cautions in the directions for use.

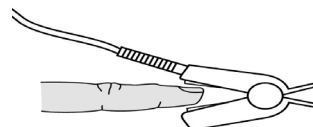

NOTE: Refer to directions for use to ensure the proper placement for various types of SpO₂ sensors.

NOTE: Periodically check to see that the sensor remains properly positioned on the resident and that skin integrity is acceptable. Refer to the sensor directions for use.

SpO₂ Sensors

Module	Item	Model	Resident Size
For Nellcor SpO ₂ Module	OXIMAX Durasensor® Oxygen transducer (Reusable, non-sterile)	DS100A	>40 kg

Description of SpO₂ Operation

The SpO₂ tile displays blood oxygen saturation level measurements and pulse amplitude. The SpO₂ tile also displays SpO₂-specific alarm status. The user can touch the SpO₂ tile to access SpO₂-specific monitor settings.

NOTE: Plethysmograph's RR function is supported by separate SW and function is activated with compatible sensor.

SpO₂ Measurement

The SpO₂ provides two display options, Pulse Amplitude and Waveform. These two options can be selected on the SpO₂ settings menu.



Figure 56. SpO₂ Tile with Pulse Amplitude

- | | | | |
|---|------------------------------------|---|----------------------------------|
| 1 | SpO ₂ Parameter Label | 4 | SpO ₂ Unit |
| 2 | SpO ₂ Measurement Value | 5 | SpO ₂ Pulse Amplitude |
| 3 | SpO ₂ Alarm Audio Icon | | |

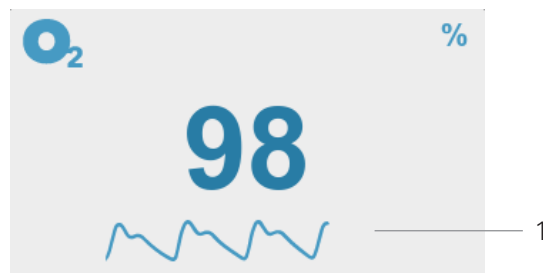

Figure 57. SpO₂ Tile with Waveform

- | | |
|---|---------------------------|
| 1 | SpO ₂ Waveform |
|---|---------------------------|

Pulse Rate Measurement with SpO₂

The Pulse Rate tile displays pulse rate measurements. The Pulse Rate tile also displays PR alarm status, and the source of the PR measurement. The user can touch the **Pulse Rate tile** to access PR-specific monitor settings



Figure 58. Pulse Rate Tile

- | | | | |
|---|------------------------------|---|-------------------|
| 1 | Pulse Rate Parameter Label | 4 | Pulse Rate Unit |
| 2 | Pulse Rate Measurement Value | 5 | Pulse Rate Source |
| 3 | Alarm Audio Icon | | |

Monitoring SpO₂ (cont.)

NOTE: Check the Pulse Rate Source setting in the **Pulse Rate Menu**. If Pulse Rate Source is set to NIBP, refer to the **Description of NIBP Operation** section.

Principle of measurement

The monitor uses pulse oximetry to measure functional oxygen saturation in the blood. Because a measurement of SpO₂ is dependent upon light from the SpO₂ sensor, excessive ambient light can interfere with this measurement. SpO₂ and Pulse rate are updated every second. This monitor measures functional saturation — oxygenated hemoglobin expressed as a percentage of the hemoglobin that can transport oxygen. It does not detect significant amounts of dysfunctional hemoglobin, such as carboxyhemoglobin or methemoglobin.

Functional versus Fractional Saturation

This monitor measures functional saturation — oxygenated hemoglobin expressed as a percentage of the hemoglobin that can transport oxygen. It does not detect significant amounts of dysfunctional hemoglobin, such as carboxyhemoglobin or methemoglobin. In contrast, hemoximeters such as the IL482 report fractional saturation — oxygenated hemoglobin expressed as a percentage of all measured hemoglobin, including measured dysfunctional hemoglobin. To compare functional saturation measurements to those from an instrument that measures fractional saturation, fractional measurements must be converted as follows:

$$\text{functional saturation} = \frac{\text{fractional saturation}}{100 - (\% \text{carboxyhemoglobin} + \% \text{methemoglobin})} \times 100$$

Measured versus Calculated Saturation

When calculating saturation from a blood gas partial pressure of oxygen (PO₂), the calculated value may differ from the SpO₂ measurement of the monitor. This usually occurs when saturation calculations exclude corrections for the effects of variables such as pH, temperature, the partial pressure of carbon dioxide (PCO₂) and 2,3-DPG, that shift the relationship between PO₂ and SpO₂.

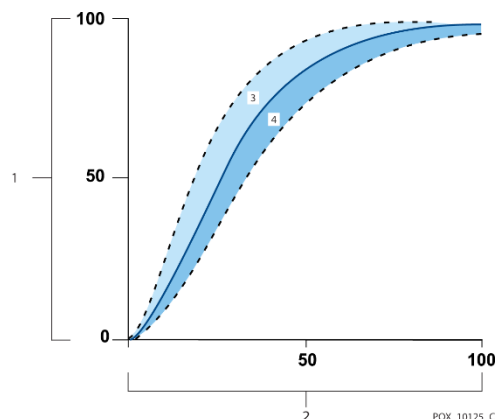

Figure 59. Oxyhemoglobin Dissociation Curve

- | | |
|-------------------------------|---|
| 1 % Saturation Axis | 3 Increased pH; Decreased temperature, PCO ₂ and 2,3-DPG |
| 2 PO ₂ (mmHg) Axis | 4 Decreased pH; Increased temperature, PCO ₂ and 2,3-DPG |

Data Upload Period, Data Averaging and Signal Processing

The advanced signal processing of the Oximax™ algorithm automatically extends the amount of data required for measuring SpO₂ and pulse rate depending on the measurement conditions. The Oximax™ algorithm automatically extends the dynamic averaging time required beyond 7 seconds during degraded or difficult measurement conditions caused by low perfusion, signal artifact, ambient light, electrocautery other interference, or a combination of these factors, which results in an increase in the dynamic averaging. If the resulting dynamic averaging time exceeds 20 seconds for SpO₂, the algorithm sets the pulse search bit while continuing to update SpO₂ and pulse rate values every seconds.

As such measurement conditions extend, the amount of data required may continue to increase. If the dynamic averaging time reaches 40 seconds and/or 50 seconds for pulse rate, a low-priority alarm state results: the algorithm sets the Pulse Timeout bit and the monitor reports a zero saturation indicating a loss-of-pulse condition, which should result in an alarm audio.

Automatic Calibration

Because light absorption by hemoglobin is wavelength dependent and because the mean wavelength of LEDs varies, an oximeter must know the mean wavelength of the *OX/MAX* sensor's red LED to accurately measure SpO₂. The wavelength range of the light emitted are near 660 nm and 890 nm with the energy not exceeding 15 mW. During monitoring, the instrument's software selects coefficients that are appropriate for the wavelength of that individual sensor's red LED; these coefficients are then used to determine SpO₂. Additionally, to compensate for differences in tissue thickness, the light intensity of the sensor's LEDs is adjusted automatically.

Clinical Studies

Clinical studied conducted for the Nellcor sensor

Overview

This appendix contains data from clinical studies conducted for the Nellcor sensors used with the monitor.

One (1) prospective, controlled hypoxia clinical study was conducted to demonstrate the accuracy of Nellcor sensors when used in conjunction with the monitor. The study was performed with healthy volunteers at a single clinical laboratory. Accuracy was established by comparison to CO-oximetry.

Methods

Data from 11 healthy volunteers were included in the analysis. Sensors were rotated on digits and brow to provide a balanced study design. SpO₂ values were continuously recorded from each instrument while inspired oxygen was controlled to produce five steady state plateaus at target saturations of approximately 98, 90, 80, 70 and 60%. Six arterial samples were taken 20 seconds apart at each plateau resulting in a total of approximately 30 samples per subject. Each arterial sample was drawn over two (2) respiratory cycles (approximately 10 seconds) while SpO₂ data were simultaneously collected and marked for direct comparison to CO₂. Each arterial sample was analyzed by at least two of the three IL CO-oximeters and a mean SaO₂ was calculated for each sample. End tidal CO₂, respiratory rate and respiratory pattern were continuously monitored throughout the study.

Monitoring SpO₂ (cont.)

Study Population

Demographic Data

Type	Class	Total
Gender	Male	5 people
	Female	6 people
Race	Caucasian	8 people
	Hispanic	2 people
	African American	1 people
	Asian	0 people
Age	-	19 ~ 48 years
Weight	-	108 ~ 250 lbs.
Skin pigment	Very light	2 people
	Olive	5 people
	Dark olive/Medium black	3 people
	Extremely dark/Blue black	1 people

Study Results

Accuracy was calculated using the root mean square difference (RMSD).

SpO₂ Accuracy for Sensors

SpO ₂ Decade	MAX-A		MAX-N		MAX-FAST	
	Data Points	Arms	Data Points	Arms	Data Points	Arms
60-70	71	3.05	71	2.89	71	2.22
70-80	55	55	55	2.32	55	1.28
80-90	48	1.84	48	1.73	48	1.48
90-100	117	1.23	117	1.68	117	0.98

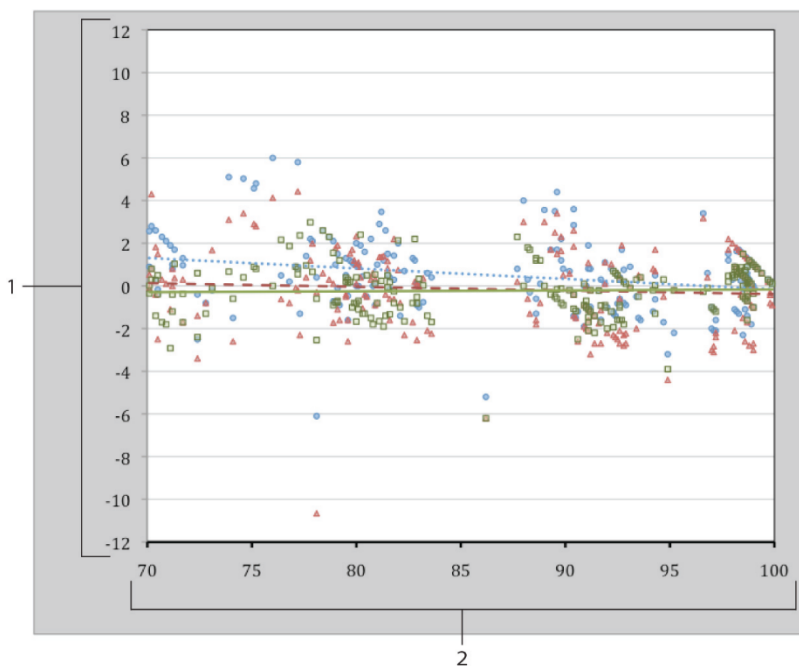

Figure 60. Modified Bland-Altman Plot

- | | |
|---|---|
| <p>1 Test Sensor:
Avg CO-oximeter value 70-100% SpO₂</p> <ul style="list-style-type: none"> ● Oximetry board with MAX-A sensor ▲ Oximetry board with MAX-N sensor ■ Oximetry board with MAX-FAST sensor | <p>2 Avg CO-oximeter value 70-100% SpO₂</p> <ul style="list-style-type: none"> ⋯ Trendline of MAX-A sensor --- Trendline of MAX-N sensor — Trendline of MAX-FAST sensor |
|---|---|

Adverse Events or Deviations

The study was conducted as expected with no adverse events and no deviations from the protocol.

Conclusion

The pooled results indicate that for a saturation range of 60-80% for SpO₂, the acceptance criterion was met for the monitor when tested with MAX-A, MAX-N and MAX-FAST sensors. The pooled results indicate that for a saturation range of 70-100% for SpO₂, the acceptance criterion was met.

Clinical Studies

Clinical studied conducted for the YM-1, YM-2, YM-5 sensors

Overview

Pulse oximetry is routinely used in clinical practice for determination of functional arterial oxygen saturation, an important physiological measurement. Validation of pulse oximeters is commonly accomplished by comparison of measurements against a co-oximeter during oxygen desaturation. Comparisons will be made between the SpO₂ measurement determined using the MD1 SpO₂ Module and a measurement calculated with oxy- and deoxyhemoglobin concentrations determined from an arterial blood sample using a co-oximeter. Monitor safety will be evaluated closely throughout the clinical investigation.

Methods

Ten subjects were studied during the clinical investigation over a 2-day period (five subjects the first day, five subjects the second day). The number of subjects chosen for the study was based on the work of Severinghaus and has been approved by the IRB of the Medical College of Wisconsin and the Milwaukee VA Medical Center. Subjects completed a case report form and signed an informed consent form prior to the clinical investigation. Any subject with health problems (i.e. diabetes, asthma), smokers or those who have not given consent could not participate in the clinical investigation. After the subjects gave informed oral and written consents, a radial artery catheter was inserted by an anesthesiologist.

Sensors were placed on both index, middle, ring and pinky fingers. The monitors were linked to a computer data acquisition system via a serial communications multiplexer.

Study Population

Demographic Data

Type	Class	Total
Gender	Male	6 people
	Female	4 people
Race	White	6 people
	Hispanic	3 people
	African American	1 people
Age	-	20 - 34 years
Weight	-	105 - 225 lb

Study Results

Accuracy was calculated using the root mean square difference (RMSD).

SpO₂ Accuracy for Sensors

SpO ₂ sensor	The total number of processed samples	Accuracy
YM-1(WA100)	566	1.708 %SpO ₂
YM-2(D-MDA)	571	1.906 %SpO ₂
YM-5(D-MDNA)	505	1.807 %SpO ₂

Conclusion

The pooled results indicate that for a saturation range of 70% to 100% for SpO₂, the acceptance criterion was met for the monitor when tested with YM-1, YM-2 and YM-5 sensors.

Monitoring Temperature

⚠ WARNING	For best product performance and measurement accuracy, use only thermometer intended for use with this monitor. Use accessories according to the manufacturer's directions for use and your facility's standards.
⚠ WARNING	Do not use damaged temperature sensors. Do not use damaged probes.
⚠ WARNING	Using a probe at the wrong site can produce inaccurate measurements and can cause resident injury.

NOTE: The user should check that the monitor is functioning while measurements are being made and check display periodically.



NOTE: Verify that the display updates after taking a measurement before accepting the displayed data as a current measurement.

Setup Connections



The monitor is designed to accept signals from the Exergen, Filac 3000, ACTT-1, and ACIT-1 thermometers. Refer to the thermometer's directions for use for additional details.

Exergen Thermometer

For adult temperature measurement

No.	Image	Description
1		Place probe flush on center of forehead and depress the red button. Keeping the button depressed slowly slide probe mid-line across forehead to the hair line.
2		Keeping button depressed, lift probe from forehead, touch behind ear halfway down the mastoid process and slide down to the soft depression behind the earlobe.
3		Release the button, remove from head and read temperature.

How to improve the accuracy of measurements on adult

No.	Image	Description
1		Measure only the up-side on a resident in a lateral position. The down-side will be insulated preventing the heat from dissipating, resulting in falsely high readings.
2		Measure straight across the forehead and not down the side of the face. At mid-line, the temporal artery is about 2mm below the surface, but can go deeply below the surface on the side of the face.
3		Brush the hair and bangs aside if covering the area to be measured.

Monitoring Temperature *(cont.)*

NOTE: According to ISO80601-2-56, Exergen thermometer is an adjusted mode thermometer.

NOTE: If needed, the probe cover can be used optionally.

Filac 3000 Thermometer

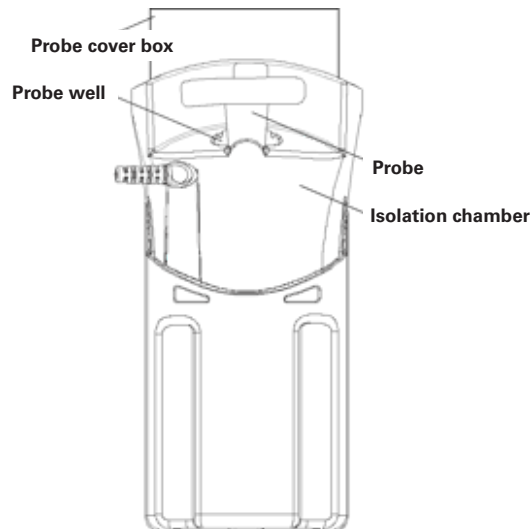

Figure 61. Filac 3000 Thermometer

Applying and removing probe covers

1. Open the probe cover box by lifting the tab at the top corner and pulling it to remove the top panel.
2. Insert the box of probe covers into the top of the isolation chamber.
3. Remove the probe from the probe well. The thermometer will automatically turn on.
4. Insert the end of the probe into a probe cover in the box. Press down the probe handle until you feel the cover snap into place.
5. Take the appropriate temperature measurement (oral or axillary).
6. Eject the used probe cover by pressing the eject button on the top of the probe.
7. Remove, discard and replace the probe cover box when empty.

NOTE: The Filac 3000 Thermometer can operate without a probe cover, but always install a probe cover prior to use to prevent cross-contamination.

Replacing isolation chamber/probe assembly

1. To remove or replace the isolation chamber/probe assembly, grasp the isolation chamber from each side.
2. Squeeze inward to release the snaps, and slide the isolation chamber off of the monitor.
3. To replace, align the probe well finger with the opening in the top of the unit.
4. Slide the isolation chamber down until the side snaps click into place.

Replacing probes

6. To replace probes, remove the isolation chamber as described previously.
7. Grasp the sides of the L-shaped connector piece with one hand and then using the other hand, pull backward on the latch holding the end of the L-shaped connector.
10. Once free of the latch, slide the L-shaped connector out of the isolation chamber.
11. To replace with a new probe, properly align the top of the L-shaped connector to the slot on the back of the isolation chamber.
12. Slide the connector up into the slot, pressing firmly on the bottom of the connector, until it clicks into place.

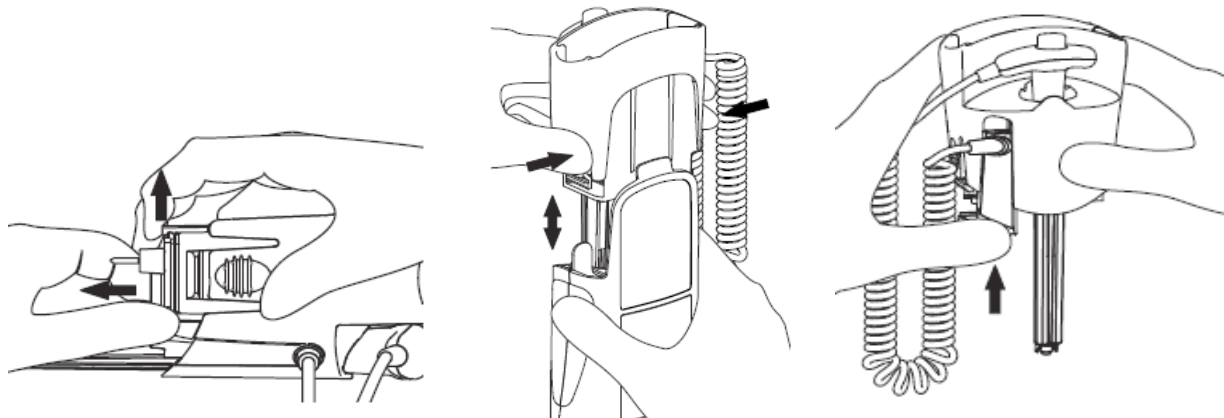

Figure 62. Method of Changing Filac 3000 Isolation Chambers and Probes

Monitoring Temperature *(cont.)*

For oral measurement

1. Make certain that the blue isolation chamber/probe unit is attached.
2. Remove the probe from the holster and attach a probe cover. The thermometer will turn on automatically when the probe is removed from the holster.
3. For oral temperatures, insert the probe tip deep into the sublingual pocket next to the frenulum linguae (vertical fold of tissue in middle of tongue) on one side or the other toward the back of the mouth.
 - Accurate body temperature readings can only be obtained in one of these two “heat pocket” locations as shown in Figure 63. Temperatures taken in other mouth locations will result in inaccurate body temperature readings.
4. Ensure the user’s mouth remains closed while the temperature is taken.
5. Securely hold the probe in place until the temperature is displayed.



Figure 63. Location of Heat Pockets

For axillary measurement

1. Have the user raise his or her arm, then place the probe tip in the axilla. Press gently to assure good contact. For the most accurate temperature, the probe tip should be placed directly against the user’s skin.
2. Have the user lower the arm and remain as still as possible. Hold the probe parallel to the arm as shown in Figure 64.

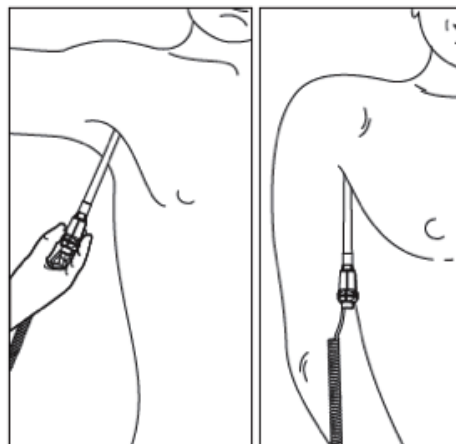

Figure 64. Filac 3000 Axillary Measurement

ACTT-1 Thermometer

⚠ WARNING	Temperature measurements can differ between left and right ears, so always measure with one ear.
⚠ WARNING	Accuracy cannot be guaranteed if there is a deformity in the ear so that the thermometer cannot be correctly inserted into the external auditory meatus, nor if the blood or the drain is in the external auditory meatus.
⚠ WARNING	If there is a medication on the ear, measure the temperature with the opposite ear.
⚠ WARNING	If earplugs or hearing aids are being worn, it must be removed and measure temperature 15 minutes later.
⚠ WARNING	Do not suck the probe or battery with mouth or touch it with wet hands.

Applying probe covers

1. Insert the probe into the new probe cover of the probe cover cassette.
2. With the clean probe cover fixed, lift the probe from the cassette. At this time, do not touch the new probe cover.

Measurement of body temperature

1. Press the Power Button. When the  indicator blinks, attach the probe cover to turn on the thermometer. When the measurement preparation is complete, the thermometer displays the last measurement.
2. Gently insert the probe with a clean probe cover attached to the outer canal.
3. Press the Scan Button. When the thermometer sounds a beep that the measurement is complete, the thermometer can be removed. The indicator blinks during measurement and turns blue when measurement is complete.
4. Check the measurement value.
5. Discard the used probe cover by pressing the Probe Cover Eject Button.

How to check the memory

1. Press the Power Button to turn on the thermometer.
2. Press the Mem Button to enter the memory mode. Whenever the Mem Button is pressed, the  indicator blinks and the measured values are displayed in the order of date. When the memory is full, the oldest result value is erased and a new result value is added. When the last reading is displayed on the LCD, user can return to the first reading by pressing the Mem Button again.
3. Press the Power Button to exit the memory mode. If user press and hold the Power Button, the power will turn off. If the thermometer is not used it for 1 minute, it will turn off automatically.

NOTE: The latest measured value is displayed first.

Replacing the battery

When the battery indicator appears, replace it with a new battery in the following order. If the battery indicator appears, it is recommended to replace the battery for accurate measurement results even if the device is operating.

1. Remove the battery cover.
2. Replace with a new battery and press until the battery is fully seated.
3. Close the battery cover.

Monitoring Temperature *(cont.)*

ACIT-1 Thermometer

⚠ WARNING	As the forehead temperature may be affected by sweat, oil and the surrounding temperature, the reading shall be taken as a reference only
⚠ WARNING	When using the thermometer, stay away from electromagnetic radiation, such as the mobile in use.
⚠ WARNING	Do not expose the device to strong electrostatic fields or strong magnetic fields to avoid affecting the measurement accuracy.
⚠ WARNING	Used in close proximity to others, EMC must be tested and verified.
⚠ WARNING	Do not try to maintain the device while it is in use.
⚠ WARNING	ACIT-1 thermometer has been calibrated at the factory. If you follow the instructions, you don't need to adjust it regularly. But if you are in doubt about the accuracy of the readings, please contact the Direct Supply.
⚠ WARNING	Always operate the thermometer in an operating temperature range 10°C to 40°C (50°F to 104°F), and relative humidity 30% to 85%.
⚠ WARNING	Always store the thermometer in a cool and dry place: temperatures between -20°C to 60°C (-4°F to 140°F); relative humidity 30% to 85%. Avoid direct sunlight.
⚠ WARNING	Avoid dropping the thermometer.
⚠ WARNING	ACIT-1 is not intended to be a substitution for a consultation with your physician.

Measurement of body temperature

1. The forehead should be clear of hair and perspiration.
2. Aim at the center forehead area 3 to 7cm away from skin surface. Be sure the thermometer is perpendicular to the skin surface.
3. Press and release the Power/Scan Button to take a measurement. A double “beep” sounds indicates a reading has been taken and displayed on the LCD screen.
4. The thermometer turns off automatically after 30 seconds.

How to change the temperature unit

1. With the thermometer off, press and hold the MODE Button for 1 second.
2. The current unit of measurement will be flashing. The default setting is in °C.
3. Press the MODE Button again to make a switch temperature unit of measurement between °C and °F.
4. When finished, press the Power/Scan Button to turn off the thermometer. The thermometer switches off automatically when left idle for 30 seconds.

How to recall past readings

1. Press and release Power/Scan Button to turn on the thermometer.
2. Press and hold the MEMORY Button for 1 second to enter the memory mode indicated by a flashing **M** indicator. The most recent reading stored will be displayed.
3. Press and release the MEMORY Button to cycle through older readings.
4. When left idle for 30 seconds, the thermometer automatically switches off.

Description of Temp Operation

The Exergen, ACTT-1, and ACIT-1 thermometers can only make spot check temperature measurements. It will not take continuous temperature measurements. The Filac 3000 thermometer can make both spot check and continuous temperature measurements. The user can touch the Temp Tile to access temperature-specific monitor settings.

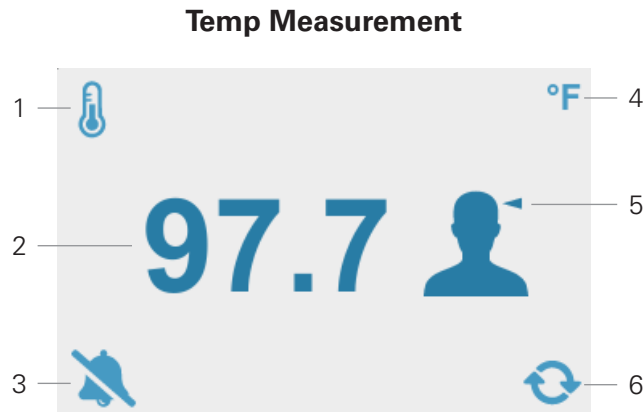

Figure 65. Temp Tile

- | | | | |
|---|------------------------|---|-----------------------|
| 1 | Temp Parameter Label | 4 | Temp Unit |
| 2 | Temp Measurement Value | 5 | Temp Measurement Site |
| 3 | Alarm Audio Icon | 6 | Temp Measurement Mode |

Principle of Measurement

Infrared method

The Exergen thermometer uses a unique method of temperature assessment, temporal artery thermometry, using infrared technology to detect the heat naturally emitted from the surface of the skin. In addition, and of key importance, this method incorporates a patented arterial heat balance system to automatically account for the effects of ambient temperature on the skin. This method of temperature assessment has been shown to improve results and reduce costs by non-invasively measuring body temperature with a degree of clinical accuracy unachievable with any other thermometry method.

The ACTT-1 thermometer uses infrared technology to detect the heat emitted from the surface of the eardrum. The thermometer captures and analyzes multiple temperature measurements, and select the most accurate to display.

The ACIT-1 thermometer uses infrared technology to detect the heat emitted from the surface of the forehead. The thermometer captures and analyzes multiple temperature measurements, and select the most accurate to display.

Thermistor Method

The Filac 3000 thermometer uses a thermistor to measure temperature. The resistance of the thermistor is inversely proportional to its temperature. By measuring the thermistor's resistance, its temperature can be calculated. The resistance of the thermistor is measured by passing a current through it and measuring the voltage developed across it.

Monitoring Temperature *(cont.)*

Measurement Mode

If the monitor is equipped with a Filac 3000 Thermometer option, the user can change the temperature measurement mode by touching the Temp Tile and selecting the desired mode. Three predict modes and one continuous mode are available:

Fast Predict Mode

Fast Predict Mode is the fastest temperature measurement mode, with the tradeoff being slightly lower accuracy. Temperature measurements in Fast Predict Mode are made in approximately 3.5 to 4 seconds.

Predict Mode

Predict Mode is the default temperature measurement mode. Predict Mode is a few seconds slower than Fast Predict Mode but is more accurate.

Cold Predict Mode

Cold Predict Mode is used for individuals with lower-than-normal body temperatures. When Cold Predict Mode is selected, the probe preheats to 91.4°F (33°C) instead of 95°F (35°C), allowing temperatures below 95°F to be measured.

Continuous Mode

In Continuous Mode, the monitor does not preheat the temperature probe and predict the final temperature value. Instead, the monitor displays the current probe temperature. The monitor may require up to 60 seconds to reach equilibrium and display the user's temperature.

Saved Readings

General

The monitor provides the data displaying, saving, deleting, exporting or printing operation. Users can save the measurement data through the **Save Button** or enter the Locally Saved Readings screen through the **Locally Saved Readings Button** to manage the measurement data. In the Locally Saved Readings screen, users can find, delete, printout the locally saved data. The data remains even if the monitor is powered off.

Saving Data Locally

The monitor saves all displayed measurement data locally when pressing the **Save Button**. If the monitor succeeds in saving, it will display an informative message confirming that the data was saved. If the monitor fails to save the data, an alarm will occur. In Spot Check Mode, after the data is saved, the monitor clears the measurement from the screen. After the monitor has stored 3,000 sets of data, the monitor will delete the oldest data set to store new data.

NOTE: In Continuous Mode, the monitor saves the measurement data whenever:

- The user presses the **Save Button**.
- A physiological alarm occurs.
- A NIBP measurement is completed or fails.

NOTE: The measurement data is not cleared when the data is saved in Continuous Mode.

NOTE: Before saving data, ensure that the vitals data was collected from the resident displayed at the top of the screen.

NOTE: After saving the data, ensure that the saved data is present in the Locally Saved Readings Screen. (Refer to the Figure 33)

Management of Locally Saved Data

The Locally Saved Data screen displays the resident name, time stamp for the data, and each of the saved vitals parameters. The Locally Saved Readings screen also allows users to delete, printout, and sort the locally saved data. The monitor displays 7 locally saved data sets on the screen at one time, and users can scroll to view additional saved data sets by pressing the **Scroll Up** and **Scroll Down Buttons**.

Deleting Locally Saved Data

To delete a locally saved data set.

1. Check the selection boxes for the data set to be deleted.
2. Press the **Delete Button**
3. A popup window will prompt the user to confirm that they want to delete the selected data. Clicking OK will delete the data. Clicking Cancel will cancel the deletion process.

NOTE: If multiple sets of data is selected, all of the selected data will be deleted at once.

NOTE: If the **Select All Button** is pressed, all of the locally saved data will be deleted at once.

NOTE: If the **Delete Button** is pressed, and no data is selected, an error tone will occur.

Printing Locally Saved Data

To print a locally saved data set

1. Check the selection boxes for the data set to be printed.
2. Press the **Print Button**, The printer will print the selected locally saved data set.

Users can cancel printing by pressing the **Print Button** during printing.

NOTE: The **Print Button** is only available when the printer option is installed.

NOTE: If the **Print Button** is pressed, and no data set is selected, an error tone will occur.

NOTE: The print function is not available if the battery is Low or Critically Low. If the **Print Button** is pressed when the battery is Low or Critically Low, an error tone will occur, and an error message will be displayed.

Printing

General

If the optional printer is installed, the monitor can print real time measurement data, locally saved data, and monitor setting information.

NOTE: *The monitor supports only English output regardless of the language setting of the monitor.*

NOTE: *The print function is not available if the battery is Low or Critically Low. If the Print Button is pressed when the battery is Low or Critically Low, an error tone will occur, and an error message will be displayed.*

Current Measurement Data Printing

When the monitor is on the Home Screen, the monitor will print vital signs measurement data each time the user presses the **Print Button**.

```
2017/05/12 12:30:59
Manual
Patient
ID : PID1234567890
Name : Jane Ryu
Location: ICU - Bed04
Birth date : 1970/12/13

NIBP : 120/ 80 ( 93) mmHg
PR(N) : 60 bpm
SpO2 : 100 %
Temp : 36.5 °C
```

Figure 66. Measurement Data Print Out

Locally Saved Data Printing

Users can print selected locally saved data sets by selecting the data set and pressing the **Print Button** on the Locally Saved Readings screen. All selected locally saved data sets can be printed in this manner.

NOTE: *If the user presses the **Print Button** on the Locally Saved Readings screen without selecting locally saved data set first, and error tone will occur.*

NOTE: *If several saved data sets are selected, all of them will be printed at once.*

2017/05/12 12:30:59 Trend print Patient ID : PID1234567890 Name : Jane Ryu Location: ICU - Bed04 Birth date : 1970/12/13 NIBP : 120/ 80 (93) mmHg PR(N) : 60 bpm SpO ₂ : 100 % Temp : 36.5 °C	2017/05/11 11:20:45 Trend print Patient ID : PID0987654321 Name : John Kim Location: ICU - Bed12 Birth date : 1966/01/01 NIBP : 120/ 80 (93) mmHg PR(N) : 60 bpm SpO ₂ : 100 % Temp : 36.5 °C	2017/05/10 10:19:12 Trend print Patient ID : PID0987654321 Name : John Kim Location: ICU - Bed12 Birth date : 1966/01/01 NIBP : 120/ 80 (93) mmHg PR(N) : 60 bpm SpO ₂ : 100 % Temp : 36.5 °C
---	---	---

Figure 67. Locally Saved Data Printing

Alarms and Limits

⚠ WARNING	Each time the monitor is used, the user should check alarm limits to make sure that they are appropriate for the resident being monitored.
⚠ WARNING	If different alarm presets are used for the same or similar equipment in any single area, e.g. an intensive care unit or cardiac room, a potential hazard can exist.
⚠ WARNING	Alarm volume adjustment is related to safety to resident. If the alarm volume is not loud enough for the clinician to hear, the clinician may not be able to recognize the resident alarm, causing risk to the resident.

General

When the monitor detects certain conditions that require user attention, the monitor enters an alarm state. The monitor response is indicated by:

- Visual alarm indication
- Audible alarm indication
- Physiological alarms including identification of out-of-limit vital signs
- Technical alarms

NOTE: *The audible and visual alarms on the monitor, used in conjunction with clinical signs and symptoms, are the primary source for notifying medical personnel that a resident alarm condition exists.*

Changing Alarm Volume

Users can select an alarm volume level of 1 to 5. Refer to the **Using the Monitor** section.

Alarm Priority

There are three possible priorities for visual and audible alarm: High, Medium and Low. The high, medium and low priority messages and the informative messages are displayed in the message tile. A message is displayed alternatively every 2 seconds when the monitor is in multiple alarm conditions. Refer to the **Service manual** for the recommended actions.

Alarm Priority Condition

Alarm Priority	Condition
High Priority	SPO2: PULSE LOST
	SYSTEM: CRITICALLY LOW BATTERY
Medium Priority	PR: HIGH ALARM LIMIT EXCEEDED
	PR: LOW ALARM LIMIT EXCEEDED
	SPO2: HIGH ALARM LIMIT EXCEEDED
	SPO2: LOW ALARM LIMIT EXCEEDED
	NIBP: HIGH SYSTOLIC ALARM LIMIT EXCEEDED
	NIBP: LOW SYSTOLIC ALARM LIMIT EXCEEDED
	NIBP: HIGH DIASTOLIC ALARM LIMIT EXCEEDED
	NIBP: LOW DIASTOLIC ALARM LIMIT EXCEEDED
	NIBP: HIGH MAP ALARM LIMIT EXCEEDED
	NIBP: LOW MAP ALARM LIMIT EXCEEDED
	TEMP: HIGH ALARM LIMIT EXCEEDED
	TEMP: LOW ALARM LIMIT EXCEEDED

Alarms and Limits *(cont.)*

Alarm Priority	Condition
Low Priority	SpO2: LOSS OF PULSE
	SpO2: SENSOR OFF OF FINGER
	SPO2: CABLE/SENSOR DISCONNECTED
	SPO2: OUT OF RANGE
	TEMPERATURE: OUT OF RANGE
	NIBP: CUFF PROBLEM DETECTED
	NIBP: MEASUREMENT FAILURE
	NIBP: MEASUREMENT TIME EXCEEDED
	NIBP: OUT OF RANGE
	MEASUREMENT DATA NOT SAVED
	PRINTER: OUT OF PAPER
	SYSTEM: LOW BATTERY
	EEE703: NIBP INTERNAL ERROR
	EEE705: NIBP INTERNAL ERROR
	EEE706: NIBP COMMUNICATION ERROR
	EEE802: TEMP COMMUNICATION ERROR
	EEE803: TEMP COMMUNICATION ERROR
	EEE804: SPO2 COMMUNICATION ERROR
	EEE807: SPO2 INTERNAL ERROR
	EEE808: SPO2 INTERNAL ERROR
	EEE809: SPO2 INTERNAL ERROR
	EEE810: SPO2 INTERNAL ERROR
	EEE811: SPO2 DEFECTIVE SENSOR
	EEE812: SPO2 INTERNAL ERROR
	EEE813: SPO2 INTERNAL ERROR
	EEE815: SPO2 INTERNAL ERROR
	EEE901: SPO2 COMMUNICATION ERROR
	EEE905: PRINTER ERROR
	EEE906: CPU COMMUNICATION ERROR
	EEE907: REAL TIME CLOCK ERROR
	EEE910: SPEAKER ERROR
	EEE911: LCD BACKLIGHT ERROR
	EEE912: CHECKSUM ERROR
EEE920: DATA CORRUPTION ERROR	
EEE903: RAM ERROR	
EEE930: BLUETOOTH ERROR	
Informative	ABNORMALLY SHUT DOWN LAST TIME
	PRINTER: NOT AVAILABLE
	PRINTER: DISABLED – LOW BATTERY
	NIBP: DISABLED – LOW BATTERY
	AUDIO ALARM OFF
	AUDIO ALARM PAUSED
	DEMO MODE
MEASUREMENT SAVED	

NOTE: *There may be other informative messages that are not listed above.*

Visual Alarm Indication

Visual Alarm Characteristics

Alarm Category	Color	Flashing Period	Duty Cycle
High priority	Red	700 ms (1.43 Hz)	On: 400 ms, Off: 300 ms
Medium priority	Yellow	2000 ms (0.5 Hz)	On: 1000 ms, Off: 1000 ms
Low priority	Yellow	N/A	Always Off

NOTE: Alarm Window on the center top of the front panel responds with the flashing rates described when an alarm occurs.

When a high priority alarm is activated, a non-flashing alarm message is displayed.

When a medium priority alarm is activated, a non-flashing alarm message is displayed.

When a low priority alarm is activated, a non-flashing alarm message is displayed.

Audible Alarm Indication

⚠ WARNING	Do not pause or terminate the alarm audio or decrease its volume if resident safety could be compromised.
⚠ WARNING	Make sure that the monitor speaker is not obstructed. Failure to do so could result in an inaudible alarm tone.
⚠ WARNING	Do not cover the speaker.

Audible Alarm Characteristics

Alarm Category	Audio Alarm Interval	Tone Pitch	Beep Rate
High priority	9 sec	540 Hz	10 beeps in 13.38 sec
Medium priority	15 sec	480 Hz	3 beeps in 16.11 sec
Low priority	30 sec	400 Hz	1 beep in 30.27 sec

NOTE: Audible alarm characteristics in Table 26 is default. Each alarm audio characteristic depends on audio alarm interval setting.

NOTE: The maximum mean time of the alarm delay is less than 10 seconds unless otherwise specified in this manual.

Alarms and Limits *(cont.)*

Changing Alarm Limits

⚠ WARNING	Each time the monitor is used, the user should check alarm limits to make sure that they are appropriate for the resident being monitored.
⚠ WARNING	If different alarm presets are used for the same or similar equipment in any single area, e.g. an intensive care unit or cardiac room, a potential hazard can exist.
⚠ CAUTION	Do not set the alarm limits to extreme values, as this may cause the alarm to become useless.

NOTE: Before reading this section, check the monitor mode. If the monitor mode is Spot Check Mode, Alarm Limit Setup is not available. This section is only available when the monitor is in Continuous Mode.

During resident monitoring, an alarm occurs when a measurement falls outside the programmed alarm limit. Alarms can be set or turned off for the following vital signs:

- Systolic high and Systolic low alarm limits
- Diastolic high and Diastolic low alarm limits
- MAP high and MAP low alarm limits
- SpO₂ high and SpO₂ low alarm limits
- PR high and PR low alarm limits
- Temp high and Temp low alarm limits

Alarm Limits Ranges

The table below describes the possible alarm limits. The monitor is shipped with factory default settings.

NOTE: Authorized personnel can define whether alarm limits are saved after the monitor is powered down. The method to do so is detailed in the service manual.

Alarm Limits Ranges

Parameter	Low Limit, Default	High Limit, Default	Resolution
Systolic (mmHg, kPa)			
Adult	30 to 265 mmHg, 90 mmHg (4.0 to 35.3 kPa, 11.9 kPa)	35 to 270 mmHg, 160 mmHg (4.6 to 35.9 kPa, 21.3 kPa)	1 mmHg (0.6 or 0.7 kPa)
Diastolic (mmHg, kPa)			
Adult	10 to 245 mmHg, 50 mmHg (1.3 to 32.6 kPa, 6.6 kPa)	15 to 250 mmHg, 90 mmHg (1.9 to 33.3 kPa, 11.9 kPa)	1 mmHg (0.6 or 0.7 kPa)
MAP (mmHg, kPa)			
Adult	20 to 255 mmHg, 60 mmHg (2.6 to 33.9 kPa, 7.9 kPa)	25 to 260 mmHg, 110 mmHg (3.3 to 34.6 kPa, 14.6 kPa)	1 mmHg (0.6 or 0.7 kPa)
SpO₂ (%)			
Adult	20 to 99%, 90%	21 to 100%, 100%	1%
PR (bpm)			
Adult	20 to 295 bpm, 50 bpm	25 to 300 bpm, 120 bpm	1 bpm
Temp (°C, °F)			
Adult	13.9 to 49.9°C, 36.0°C (57.0 to 121.8°F, 96.8°F)	14.0 to 50.0°C, 39.0°C (57.2 to 122.0°F, 102.2°F)	0.1°C (0.1 or 0.2°F)

Setting Alarm Limits

Alarm Limits determine the high and low points of resident data at which the monitor will sound an alarm. Users can change the alarm limits of each parameter. Alarms menu can be accessed by pressing the tile of each parameter or via Settings.

NIBP Alarms Menu

Alarm Setting	Value/Submenu
SYS high/low thresholds	Opens the numeric keypad
SYS audio alarm	On, Off
MAP high/low thresholds	Opens the numeric keypad
MAP audio alarm	On, Off
DIA high/low thresholds	Opens the numeric keypad
DIA audio alarm	On, Off

SpO₂ Alarms Menu

Alarm Setting	Value/Submenu
SpO ₂ high/low thresholds	Opens the numeric keypad
SpO ₂ audio alarm	On, Off

Pulse Rate Alarms Menu

Alarm Setting	Value/Submenu
Pulse Rate high/low thresholds	Opens the numeric keypad
Pulse Rate limits audio alarm	On, Off

Temperature Alarms Menu

Alarm Setting	Value/Submenu
Temp high/low thresholds	Opens the numeric keypad
Temp audio alarm	On, Off

Pausing Audio Alarms/Turning Audio Alarms On/Off

⚠ WARNING

If an alarm condition occurs while in the Alarm Audio Off state, the only alarm indication on the monitor will be visual displays related to the alarm condition.

1. To pause an audio alarm in progress, press the **Audio Alarm Pause/Off Button**.
2. To un-pause an audio alarm in progress, press the **Audio Alarm Pause/Off Button**.
3. To turn off audio alarms, press and hold the **Audio Alarm Pause/Off Button**.
4. To turn audio alarms back on, press and hold the **Audio Alarm Pause/Off Button**.

Menu Structure

SETTINGS

- NIBP
 - INITIAL INFLATION PRESSURE
 - AUTO
 - 120 mmHg
 - 140 mmHg
 - 160 mmHg
 - 180 mmHg
 - 200 mmHg
 - 220 mmHg
 - 240 mmHg
 - 260 mmHg
 - NIBP UNITS
 - mmHg
 - kPa
 - MAP DISPLAY
 - OFF
 - ON
 - NIBP INTERVAL (Continuous mode only)
 - OFF
 - CONT
 - 1 min
 - 2 min
 - 2.5 min
 - 5 min
 - 10 min
 - 15 min
 - 30 min
 - 60 min
 - 120 min
 - NIBP ALARMS (Continuous mode only)
 - SYS high
 - 35 - 270 mmHg (Adult, 1 mmHg step)
 - SYS low
 - 30 - 265 mmHg (Adult, 1 mmHg step)
 - SYS limit audio alarm
 - ON
 - OFF
 - MAP high
 - 25 - 260 mmHg (Adult, 1 mmHg step)
 - MAP low
 - 20 - 255 mmHg (Adult, 1 mmHg step)
 - MAP limit audio alarm
 - ON
 - OFF
 - DIA high
 - 15 - 250 mmHg (Adult, 1 mmHg step)
 - DIA low
 - 10 - 245 mmHg (Adult, 1 mmHg step)
 - DIA limit audio alarm
 - ON
 - OFF

- **TEMPERATURE**
- • **MEASUREMENT MODE (If Filac 3000 thermometer option is installed)**
- • • **PREDICT**
- • • **FAST PREDICT**
- • • **COLD PREDICT**
- • • **CONTINUOUS**
- • **MEASUREMENT SITE (If Filac 3000 thermometer option is installed)**
- • • **ORAL**
- • • **AXILLARY**
- • **MEASUREMENT UNITS**
- • • **F**
- • • **C**
- • **TEMPERATURE ALARMS (Continuous mode only)**
- • • **TEMPERATURE high (Installed Thermometer)**
- • • • **14.0 - 50.0 °C (Adult, 0.1 °C step)**
- • • **TEMPERATURE low (Installed Thermometer)**
- • • • **13.0 - 49.9 °C (Adult, 0.1 °C step)**
- • • **TEMPERATURE limit audio alarm**
- • • • **ON**
- • • • **OFF**
- **PULSE RATE**
- • **PULSE RATE SOURCE**
- • • **AUTO**
- • • **NIBP**
- • • **SPO2**
- • **PULSE RATE ALARMS (Continuous mode only)**
- • • **PULSE RATE high**
- • • • **25 - 300 bpm (Adult, 1 bpm step)**
- • • **PULSE RATE low**
- • • • **20 - 295 bpm (Adult, 1 bpm step)**
- • • **PULSE RATE limit audio alarm**
- • • • **ON**
- • • • **OFF**
- **SPO2**
- • **SPO2 VIEW**
- • • **PULSE AMPLITUDE**
- • • **WAVEFORM**
- • **SWEEP SPEED**
- • • **12.5 mm/s**
- • • **25.0 mm/s**
- • **SPO2 ALARMS (Continuous mode only)**
- • • **SPO2 high**
- • • • **21 - 100 % (Adult, 1 % step)**
- • • **SPO2 low**
- • • • **20 - 99 % (Adult, 1 % step)**
- • • **SPO2 limit audio alarm**
- • • • **ON**
- • • • **OFF**
- **MODE**
- • **OPERATION MODE**
- • • **SPOT CHECK**
- • • **CONTINUOUS**

Menu Structure *(cont.)*

- **DISPLAY**
- • **BRIGHTNESS**
- • • 1 - 5
- • **MENUTIMEOUT**
- • • OFF
- • • 10 SEC
- • • 20 SEC
- • • 30 SEC
- • • 40 SEC
- • **SLEEP MODE**
- • • OFF
- • • 5 MIN
- • • 10 MIN
- • • 20 MIN
- • • 30 MIN
- **SOUND**
- • **KEY BEEP VOLUME**
- • • OFF
- • • 1 - 5
- • **PULSE TONE VOLUME**
- • • OFF
- • • 1 - 5
- • **OTHER SOUND VOLUME**
- • • OFF
- • • 1 - 5
- • **COMPLETION SOUND**
- • • ON
- • • OFF
- • **ALARM VOLUME**
- • • 1 - 5
- **DATE/TIME**
- • **MONTH**
- • • 1 - 12
- • **DAY**
- • • 1 - 28
- • • 1 - 29
- • • 1 - 30
- • • 1 - 31
- • **YEAR**
- • • 2020 ~ 2035
- • **HOUR**
- • • 0 - 23
- • **MINUTE**
- • • 0 - 59
- **STORAGE**
- • **DATA STORAGE**
- • • OFF
- • • ANONYMOUS
- • • RESIDENT
- • **AUTO DELETE AFTER**
- • • 1 DAY
- • • 1 WEEK
- • • 1 MONTH
- • • 1 YEAR

- • • NEVER
- SERVICE
- • PASS CODE
- • • (Input status)
- • • • Numeric Keyboard
- • • • OK
- • • • Cancel

HELP

- NIBP
- ORAL TEMPERATURE
- TYMPANIC TEMPERATURE
- TEMPORAL TEMPERATURE
- SPO2
- ICONS
 - • NIBP PARAMETER
 - • TEMPERATURE PARAMETER
 - • PULSE RATE PARAMETER
 - • SPO2 PARAMETER
 - • PARAMETER ALARM(S) DISABLED
 - • TEMPERATURE PROBE LOCATION (ORAL/AXILLARY/RECTAL)
 - • TEMPERATURE PROBE IN COLD PREDICT MODE (SLOWER)
 - • TEMPERATURE PROBE IN WARM PREDICT MODE (FASTER)
 - • PULSE RATE READING ACQUIRED FROM SPO2
 - • PULSE RATE READING ACQUIRED FROM NIBP
- ADDITIONAL INFORMATION
 - • PRODUCT MODEL #
 - • SERIAL NUMBER
 - • MANUFACTURE DATE
 - • SYSTEM VERSION
 - • KERNEL VERSION
 - • SOFTWARE VERSION
 - • SUB-CPU VERSION
 - • MONITOR USAGE
 - • BATTERY USAGE
 - • CRITICAL BATTERY
 - • NIBP MODULE VERSION
 - • NIBP MEASUREMENTS
 - • SPO2 MODULE VERSION
 - • SPO2 MODULE USAGE
 - • TEMP MODULE VERSION
 - • TEMP MEASUREMENTS
 - • TEMP PROBE SERIAL #
 - • PRINT VERSION
 - • PRINTER USAGE

SERVICE

- POWER ON SETTINGS
 - • BACK UP
 - • CUSTOM
 - • FACTORY DEFAULT

Menu Structure *(cont.)*

- LANGUAGE
 - ENGLISH
 - SPANISH
 - FRENCH
- SYSTEM UPDATE
 - KERNEL UPDATE
 - UPDATE
 - SUB-CPU UPDATE
 - UPDATE
 - BLUETOOTH BROADCAST NAME UPDATE
 - THERMOMETER PAIRING
- SYSTEM TESTS
 - LCD TEST
 - TOUCHSCREEN TEST
 - TOUCHSCREEN CALIBRATION
 - SWITCH/LED TEST
 - SOUND TEST
 - NIBP TEST
- ALARM SETTINGS
 - ALARM PAUSE TIME
 - DISABLE
 - 1 MIN
 - 3 MIN
 - 5 MIN
 - 10 MIN
 - 20 MIN
 - 30 MIN
 - 60 MIN
 - INDEFINITE
 - ALARM REMINDER TIME
 - OFF
 - 3 MIN
 - 10 MIN
- ALARM INTERVALS
 - HIGH PRIORITY
 - 3 SEC
 - 9 SEC
 - 15 SEC
 - MEDIUM PRIORITY
 - 3 SEC
 - 15 SEC
 - 30 SEC
 - LOW PRIORITY
 - 15 SEC
 - 30 SEC
 - 60 SEC
- ERROR LOGS
- DEMO MODE
 - ON
 - OFF

Maintenance

⚠ WARNING	The cover should be removed only by qualified service personnel. There are no internal user-serviceable parts except for the battery.
⚠ WARNING	Do not spray, pour, or spill any liquid on the monitor, its accessories, connectors, switches or openings in the chassis.
⚠ WARNING	Unplug the power cord from the monitor before cleaning the monitor.

Recycling and Disposal

When the monitor, battery or accessories reach the end of useful life, recycle or dispose of the equipment according to appropriate local and regional regulations.

NOTE: *The monitor should be disposed of separately from the municipal waste stream via designated collection facilities appointed by the government or the local authorities.*

NOTE: *The correct disposal of your old appliance will help prevent potential negative consequences for the environment and human health.*

NOTE: *For more detailed information about disposal of your old appliance, please contact your city office, waste disposal service or Direct Supply.*

Returning the Monitor and System Components

Contact Direct Supply for shipping instructions. Pack the monitor with sensor, cable and other accessory items in its original shipping carton. If the original carton is not available, use a suitable carton with appropriate packing material to protect the monitor during shipping. Ship the monitor according to instructions received from Direct Supply.

Service

The monitor requires no routine service other than cleaning, battery maintenance and service activity, which is mandated by the user's institution. For more information, refer to the monitor service manual. Qualified service personnel in the user's institution should perform periodic inspections of the monitor. If service is necessary, contact Direct Supply.

Periodic Safety Checks

It is recommended that the following checks be performed every year.

- Inspect the equipment for mechanical and functional damage.
- Inspect the external safety labels for legibility.

Cleaning

The monitor may be surface-cleaned by using a soft cloth dampened with either a commercial, nonabrasive cleaner or one of the solutions listed below. Lightly wipe the top, bottom and front surfaces of the monitor.

- 70% Isopropyl alcohol
- 10% Chlorine bleach solution
- Quaternary Ammonium (fungicidal, bactericidal and virucidal against enveloped viruses)
- PDI Sani-System

Maintenance *(cont.)*

For cables, sensors, cuffs and probes, follow the cleaning instructions in the directions for use shipped with those components.

Avoid spilling liquid on the monitor, especially in connector areas. If liquid is accidentally spilled on the monitor, clean and dry thoroughly before reuse. If in doubt about the monitor safety, contact Direct Supply.

Battery Maintenance

⚠ CAUTION	Recharging the battery is strongly recommended when the battery has not been recharged for 2 or more months.
⚠ CAUTION	Follow local government ordinances and recycling instructions regarding disposal or recycling of device components, including battery.
⚠ CAUTION	Do not short-circuit the battery, as it may generate heat. To avoid short-circuiting, do not let the battery come in contact with metal objects at any time, especially when transporting.
⚠ CAUTION	Do not solder the battery directly. Heat applied during soldering may damage the safety vent in the battery's positive cover.
⚠ CAUTION	Do not deform the battery by applying pressure. Do not throw, hit, drop, fold or impact the battery.
⚠ CAUTION	Do not connect the battery reversed in positive (+) and negative (-) terminals. Do not charge the battery with polarities reversed, as it may swell or explode.
⚠ CAUTION	Do not use any external chargers with the monitor battery.
⚠ CAUTION	Do not use the battery with other manufacturer's batteries. Using different types or models of batteries such as dry batteries, nickel-metal hydride batteries, or Li-ion batteries together, as they might leak electrolyte heat or explode.
⚠ CAUTION	Do not damage the battery or use the battery in any other applications.
⚠ CAUTION	Keep the battery out of reach of babies and children to avoid any accidents.
⚠ CAUTION	If there are any problems with the battery, immediately put the battery in a safe place and contact Direct Supply.
⚠ CAUTION	The battery may be depleted due to self-discharge for a long storage. Recharge the battery when the device is initially installed.
⚠ CAUTION	The partial charge of a battery results in a shortened battery life.

If the monitor has not been used for 2 months, the Li-ion battery will need to be charged. To charge the battery, connect the monitor to an AC power source as described in the **Battery Operation** section.

NOTE: Storing the monitor for a long period without charging the battery may degrade the battery capacity. A full charge of a depleted battery takes over 12 hours.

NOTE: The battery should be removed from the monitor if placed in storage or if it will not be used for a long period.

It is recommended that the monitor's Li-ion battery be replaced every 6 months. Refer to the service manual for battery replacement and general service instructions.

Loading Printer Paper

⚠ CAUTION Only use printer paper intended for use with this monitor.

NOTE: *The paper roll is easier to load if it is held horizontally with your thumb on top and your forefinger and/or index finger underneath it.*

Load printer paper as follows:

1. Open the printer door by pulling the latch on the printer slightly and carefully. The door should tilt open. Gently pull the door open if necessary.
2. Reach in and remove the empty paper core by pulling it over gently with your thumb and index finger.
3. Insert a new paper roll in the correct orientation.
4. Pull the paper out towards you until approximately 2 inches (5 cm) of paper have been unrolled.
5. Align the paper with the pinch roller attached to the printer door.
6. Close the printer door.

NOTE: *To make sure that the paper is aligned in the slot and has not been pinched in the door, pull the loose edge until a few inches of paper is showing. If the paper will not move, open the door and return to step 4.*

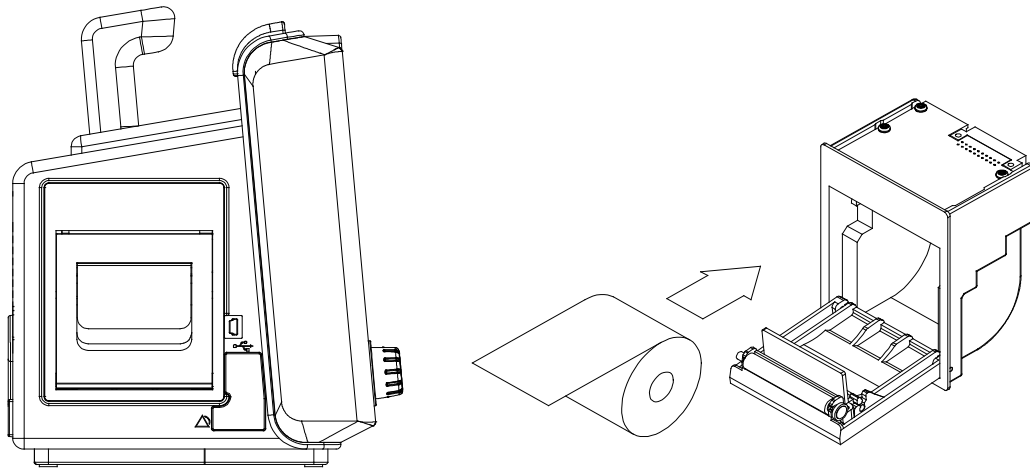

Figure 68. Printer Paper Replacement

Troubleshooting

⚠ WARNING	If you are uncertain about the accuracy of any measurement, check the resident's vital signs by an alternate means, then make sure the monitor is functioning correctly.
⚠ WARNING	The cover should only be removed by qualified service personnel. There are no user-serviceable parts inside except for the battery.

General

If the monitor detects an error, it will display an error code. The error codes are listed in the monitor service manual. If an error code is displayed, write down the code and contact Direct Supply. Before calling Direct Supply, make sure that the battery is charged and that all power connections are in place.

Corrective Action

If you experience a problem while using the monitor and are unable to correct it, contact Direct Supply. The service manual provides additional troubleshooting information for qualified personnel.

Following is a list of possible errors and suggestions for corrective action.

Error	Corrective Action
No response to pressing the Power button.	Press the <i>Power Button</i> . Verify that the battery is installed and the monitor is connected to an AC power source. Verify that the Battery Charging Indicator is lit. If the error continues, contact Direct Supply.
Monitor does not power on with battery.	Check the battery installation. Check the Battery Charging Indicator is lit. Recharge the battery for 12 hours. If the condition persists, replace the battery.
Low Battery / Critically Low-Battery condition.	Connect the monitor to AC power source and verify the Battery Charging Indicator is lit. Replace the battery. If the error continues, contact Direct Supply.
Display is deformed or not displayed.	Contact Direct Supply.
No sound produced by the monitor.	Verify the volume setting is loud enough to hear. Verify the alarm audio is not paused. If the error continues, contact Direct Supply.
Date and Time incorrect.	Set the date and time from the Date and Time menu. Turn off the monitor for a few minutes, and then power it back on. Verify the data and time is set properly. If the error continues, contact Direct Supply.
Abnormally shut down last time.	Contact Direct Supply.
Technical System Error (ex. EEE801~)	Do not use the monitor. Contact Direct Supply.
Buzzing sound is heard, and the monitor cannot be turned off.	If the monitor is in an abnormal situation, the monitor may be forcibly shut down by pressing and holding the <i>Power Button</i> for 15 seconds or more. Contact Direct Supply.

Error	Corrective Action
SpO ₂ loss of pulse error	<p>Check perfusion at the measurement site. Verify that the sensor is applied properly. Verify that the sensor site has a pulse. Relocate the sensor to another site with improved circulation. If the error occurs due to NIBP measurement on the same limb, wait for the NIBP measurement to complete before taking the SpO₂ reading. Try another sensor.</p>
SpO ₂ signal is not displayed.	<p>Check the connection between the sensor and the sensor cable. Check for damage on the sensor and sensor cable. Try another sensor.</p>
SpO ₂ signal is poor.	<p>Check the sensor and sensor positioning. Verify that skin pigment is not causing the issue. Make sure that the resident is not moving. Check for damage on the sensor and sensor cable. Make sure the sensor cable is not positioned too close to power cables.</p>
The pump operates, but the cuff does not inflate or fails to inflate fully.	<p>Check the Resident Type (adult). Check the NIBP hose and cuff connections, if needed. Replace the cuff.</p>
NIBP measurements appear High / Low.	<p>Verify that the correct cuff size is being used. Verify correct NIBP cuff positioning. The resident should not talk and not move during the measurements. If the error continues, contact Direct Supply.</p>
NIBP Measurement does not work	<p>Verify that the cuff hose is not bent, stretched, compressed or loose. Prevent motion artifacts. Use the correct cuff size. If the error continues, contact Direct Supply.</p>
Temperature measurement does not work, or measurement values are in doubt.	<p>Verify the temperature unit setting. Verify that the correct probe is being used. Check for probe damage. Try another probe. If the error continues, contact Direct Supply.</p>
Printer Paper won't move.	<p>Reload paper or clear jam. If paper is wet, replace with fresh, dry roll. Use only recommended paper type.</p>
Paper moves then stops.	<p>Check door latch. Replace the battery with new battery. If the battery is low, connect the monitor to an AC power source. Reload paper or clear jam.</p>
The device name is not displayed when performing BLE scan on the tablet.	<p>Check that the power LED of the Bluetooth module is on. If the Bluetooth indicator shows that a connection has already been made, disconnect the previous connection.</p>

Troubleshooting *(cont.)*

EMI (Electromagnetic Interference)

⚠ WARNING	Keep residents under close surveillance when monitoring. It is possible, although unlikely, that radiated electromagnetic signals from sources external to the resident and monitor can cause inaccurate measurement readings. Do not rely entirely on the monitor readings for resident assessment.
⚠ WARNING	It is possible that any radio frequency transmitting equipment and other nearby sources of electrical noise may result in disruption in the monitor operation.
⚠ WARNING	It is possible, although unlikely, that large equipment using a switching relay for its power on/off may affect monitor operation. Do not operate the monitor in such environments.

The monitor has been tested and found to comply with the limits for medical devices to the IEC60601-1-2 and Medical Device Directive 93/42/EEC. These limits are designed to provide reasonable protection against harmful interference in a typical medical setting.

However, because of the proliferation of radio-frequency transmitting equipment and other sources of electrical noise in healthcare environments (such as electrosurgical equipment, defibrillator, cellular phones, mobile two-way radios, electrical appliances and high-definition television), it is possible that high levels of such interference due to close proximity or strength of a source may affect monitor operation.

⚠ WARNING	The monitor is designed for use in environments in which the signal can be obscured by electromagnetic interference. During such interference, measurements may seem inappropriate or the monitor may not seem to operate correctly.
------------------	--

Monitor disruption may be indicated by erratic readings, cessation of operation or other incorrect functioning. If this occurs, survey the site to determine the source of this disruption. Try the following actions to see if they eliminate the disruption:

- Turn equipment in the vicinity off and on to isolate the offending equipment.
- Reorient or relocate the interfering equipment.
- Increase the separation between the interfering equipment and the monitor.

The monitor generates, uses and can radiate radio frequency energy. If the monitor is not installed and used in accordance with these instructions, the monitor may cause harmful interference with other devices in the vicinity.

If assistance is required, contact Direct Supply.

Obtaining Technical Assistance

For technical information and assistance, or to order the monitor service manual, call Direct Supply. The service manual provides information required by qualified service personnel when servicing the monitor. When calling Direct Supply, you may be asked to provide the software version number of your monitor. This is viewable in the Help Menu under Additional Info.

Factory Defaults

General

The monitor is shipped with factory default settings. Authorized personnel can use the procedures described in the service manual to change default settings.

Parameter Ranges and Default Settings

Parameter Ranges and Factory Defaults

Parameter	Ranges/Selections	Factory Defaults
NIBP		
Initial Inflation Pressure	Auto, 120, 140, 160, 180, 200, 220, 240, 260, 280 mmHg	Auto
NIBP Units	mmHg, kPa	mmHg
MAP Display	Off, On	Off
NIBP Interval	Off, Cont, 1, 2, 2.5, 5, 10, 15, 30, 60, 120 min	Off
NIBP SYS Upper Alarm Limits	35 to 270 mmHg 4.7 to 36.0 kPa (1 mmHg / 0.6 or 0.7 kPa steps)	160 mmHg 21.4 kPa
NIBP SYS Lower Alarm Limits	30 to 265 mmHg 4.0 to 35.4 kPa (1 mmHg / 0.6 or 0.7 kPa steps)	90 mmHg 12.0 kPa
NIBP SYS Limit Audio Alarm	Off, On	On
NIBP MAP Upper Alarm Limits	25 to 260 mmHg 3.4 to 34.7 kPa (1 mmHg / 0.6 or 0.7 kPa steps)	110 mmHg 14.7 kPa
NIBP MAP Lower Alarm Limits	20 to 255 mmHg 2.7 to 34.0 kPa (1 mmHg / 0.6 or 0.7 kPa steps)	60 mmHg 8.0 kPa
NIBP MAP Limit Audio Alarm	Off, On	On
NIBP DIA Upper Alarm Limits	15 to 250 mmHg 2.0 to 33.4 kPa (1 mmHg / 0.6 or 0.7 kPa steps)	90 mmHg 12.0 kPa
NIBP DIA Lower Alarm Limits	10 to 245 mmHg 1.4 to 32.7 kPa (1 mmHg / 0.6 or 0.7 kPa steps)	50 mmHg 6.7 kPa
NIBP DIA Limit Audio Alarm	Off, On	On

Factory Defaults *(cont.)*

Parameter	Ranges/Selections	Factory Defaults
Temperature		
Measurement Mode	Predict, Fast Predict, Cold Predict, Continuous	Predict*
Measurement Site	Oral, Axillary	Oral*
Measurement Units	F, C	F
Temp Upper Alarm Limits	14.0 to 50.0 °C (0.1° C steps) 57.2 to 122.0°F (0.1 or 0.2 °F steps)	39.0 °C (102.2 °F)
Temp Lower Alarm Limits	13.9 to 49.9 °C (0.1° C steps) 57.0 to 121.8°F (0.1 or 0.2 °F steps)	36.0 °C (96.8 °F)
Temp Limit Audio Alarm	Off, On	On
Pulse Rate		
Pulse Rate Source	Auto, NIBP, SpO ₂	Auto
Pulse Rate Upper Alarm Limits	25 to 300 bpm (1 bpm steps)	120 bpm
Pulse Rate Lower Alarm Limits	20 to 295 bpm (1 bpm steps)	50 bpm
Pulse Rate Limit Audio Alarm	Off, On	On
SpO₂		
SpO ₂ View	Pulse amplitude, Waveform	Pulse amplitude
Sweep Speed	12.5 mm/s, 25.0 mm/s (Set Waveform view)	25.0 mm/s
%SpO ₂ Upper Alarm Limits	21 to 100 % (Adult/Pedi/Neo) (1 % steps)	100 %
%SpO ₂ Lower Alarm Limits	20 to 99 % (Adult/Pedi/Neo) (1 % steps)	90 %
%SpO ₂ Limit Audio Alarm	Off, On	On
Mode		
Operation Mode	Spot Check, Continuous	Spot Check
Display		
Brightness	1, 2, 3, 4, 5	4
Menu Timeout	Off, 10 sec, 20 sec, 30 sec, 40 sec	10 sec
Sleep Mode	Off, 5 min, 10 min, 20 min, 30 min	Off

* For Filac 3000 Thermometer option only

Parameter	Ranges/Selections	Factory Defaults
Sound		
Key Beep Volume	Off, 1, 2, 3, 4, 5	1
Pulse Tone Volume	Off, 1, 2, 3, 4, 5	Off
Other Sound Volume	Off, 1, 2, 3, 4, 5	1
Completion Sound	Off, On	On
Alarm Volume	1, 2, 3, 4, 5	2
Data/Time		
Month	1 ~ 12	6
Day	1 ~ 28, 1 ~ 29, 1 ~ 30, 1 ~ 31	15
Year	2020 ~ 2035	2020
Hour	0 ~ 23	12
Minute	0 ~ 59	30
Storage		
Data Storage	Off, Anonymous, Resident	Off
Auto Delete After	1 Day, 1 Week, 1 Month, 1 Year, Never	Never
Other		
Power On Setting	Back Up, Custom, Factory Default	Factory Default
Language	English, Spanish, French	English
Alarm Pause Time	Disable, 1 min, 3 min, 5 min, 10 min, 20 min, 30 min, 60 min, Indefinite	3 min
Alarm Mute Time	30 sec, 60 sec, 90 sec, 120 sec	120 sec
Alarm Reminder Time	Off, 3 min, 10 min	3 min
High Priority Interval	3 sec, 9 sec, 15 sec	9 sec
Medium Priority Interval	3 sec, 15 sec, 30 sec	15 sec
Low Priority Interval	15 sec, 30 sec, 60 sec	30 sec
Demo Mode	Off, On	Off

Specification

Display

Screen Size	8" TFT-LCD Screen
Screen Type/Color	Liquid Crystal Display (LCD) 24 bit RGB Color
Resolution	800 x 480 pixel
Language	English

Controls

Standard	Touch Screen Knob 6 Buttons (Power Button, NIBP Start/Stop Button, NIBP Interval Setting Button, Print Start/Stop Button, Home Button, Audio Alarm Pause/Off Button)
----------	--

Alarms

Categories	Resident Alarms and System Alarms
Priorities	Low, Medium, High Priorities and Informative
Notification	Audible and Visual
Setting	Default and Individual
Alarm Volume Level	45 to 85 dB
Distributed Alarm System Delay	Less than 3 sec

Wireless Communication

Bluetooth

Type	Bluetooth® Low Energy Controller, IEEE 802.15.4
Transmission power	6.1 to 9.1mA
Mode	Slave mode NOTE: <i>Measurements data and device control commands excluding system information operate only when pairing is performed by entering a 6-digit pin code.</i>
RF section	97 dBm for BLE 100 dBm for IEEE 802.15.4 Selectivity and Blocking performance
Operating frequency	2402 MHz to 2480 MHz, 40 channels
Security	AES-128
Recommend operating distances	Without obstacles: 10m With obstacles: 3m

Physical Characteristics and Printer

Instrument	
Dimensions	307 x 236 x 198 (mm) (WxHxD) (for Exergen thermometer installed monitor) 298 x 211 x 185 (mm) (WxWxD) (for Filac 3000 thermometer installed monitor) 311 x 211 x 190 (mm) (WxWxD) (for ACTT-1 thermometer installed monitor) 311 x 211 x 176 (mm) (WxWxD) (for ACIT-1 thermometer installed monitor) 360 x 211 x 190 (mm) (WxWxD) (for ACTT-1/Filac 3000 thermometer installed monitor) 360 x 211 x 185 (mm) (WxWxD) (for ACIT-1/Filac 3000 thermometer installed monitor)
Weight	Approx. 3.5kg (for Exergen thermometer installed monitor) Approx. 3.4kg (for Filac 3000 thermometer installed monitor) Approx. 3.4kg (for ACTT-1 thermometer installed monitor) Approx. 3.3kg (for ACIT-1 thermometer installed monitor) Approx. 3.7kg (for Filac 3000 and ACTT-1 thermometer installed monitor) Approx. 3.6kg (for Filac 3000 and ACIT-1 thermometer installed monitor)
Degree of Protection against Electric Shock	NIBP: Type CF with defibrillator protection SpO ₂ : Type CF with defibrillator protection Filac 3000: Type CF with defibrillator protection Temp: Exergen: Type BF with defibrillator protection ACTT-1: Type BF ACIT-1: Type BF
Parts which contact the human body	NIBP: Cuff SpO ₂ : Inner rubber parts and window of SpO ₂ sensor Temp: Temperature probe
Mode of Operation	Spot check, Continuous
Liquid ingress	IPX2: Protection against vertically dripping water
Classification	AVSM3 SNF: Class IIb (MDD Annex IX Rule10: MEDDEV 2.4/1 Rev.9)

Printer (option)

Type	Thermal
Weight	180g (without the printer paper)
Resolution	320 dots/line (about 200 DPI)
Number of Channels	1 channel
Paper Type	Thermal
Paper Width	50 mm
Printer Speeds	25 mm/s

Electrical Characteristics

Instrument	
Power Requirements	AC Mains 100Vac to 240Vac, 50/60 Hz, 93VA to 120VA

Battery (option)

Type	Li-ion battery
Operating time	8 hours (6600 or 6450 mAh) <i>Under the following conditions:</i> <i>No alarm audio</i> <i>No data output</i> <i>No communication (Bluetooth module is installed)</i> <i>No printing out (Printer module is installed)</i> <i>All monitoring parameters are active</i> <i>NIBP measurement per 15 minutes</i> <i>LCD Brightness: default</i> <i>Ambient temperature at 25°C</i>
Voltage/Capacity	10.8 V / 6600 mAh or 10.95 V / 6450 mAh
Recharge Time	12 hours for depleted battery to 90% of battery capacity and for full recharge with monitor turned on/off.
Life Cycle	6 months, new battery fully-charged After 2 months storage the monitor would run for 50% of stated battery life.

Specification *(cont.)*

Environmental Conditions

Operation

Temperature	5 to 40°C (41 to 104°F) Exergen thermometer: 16 to 39.5°C (60.8 to 103.1°F) Filac 3000 thermometer: 10 to 40°C (50 to 104°F) ACTT-1 thermometer: 10 to 40°C (50 to 104°F) ACIT-1 thermometer: 10 to 40°C (50 to 104°F)
Humidity	15 to 93% RH, non-condensing Exergen thermometer: 1 to 90% RH, non-condensing ACTT-1 thermometer: 95% RH or less non-condensing ACIT-1 thermometer: 30 to 85% RH, non-condensing
Atmospheric pressure (Altitude)	580 to 1013 hPa (0 m (0 ft) to 4464.4 m (14,646 ft) at 15°C)

Transport and Storage (in shipping container)

Temperature	-20°C to 60°C (-4°F to 140°F) NOTE: <i>The battery should be separated from monitor when continuously storing the monitor for more than 1 month.</i> NOTE: <i>The battery should be charged before using the monitor if the monitor is stored with the battery for more than 1 month.</i>
Humidity	15 to 93% RH, non-condensing Exergen thermometer: 1 to 90% RH, non-condensing ACTT-1 thermometer: 95% RH or less non-condensing ACIT-1 thermometer: 30 to 85% RH, non-condensing
Atmospheric pressure (Altitude)	500 to 1013 hPa (0 m (0 ft) to 5574.44 m (18,288 ft) at 15°C)
NOTE: <i>The system may not meet its performance specifications if stored or used outside the specified temperature and humidity range.</i>	

Alarm Tone Definition

High Priority Alarm Tone

Volume level	Adjustable (level 1~5)
Pitch ($\pm 5\%$)	540 Hz
Pulse width ($\pm 5\%$)	130 msec
Number of pulses	10 pulses per 9 sec, 7.38 sec inter burst (selectable)
Repetitions	Continually

Medium Priority Alarm Tone

Volume level	Adjustable (level 1~5)
Pitch ($\pm 5\%$)	480 Hz
Pulse width ($\pm 5\%$)	180 msec
Number of pulses	3 pulses per 15 sec, 16.11 sec inter burst (selectable)
Repetitions	Continually

Low Priority Alarm Tone

Volume level	Adjustable (level 1~5)
Pitch ($\pm 5\%$)	400 Hz
Pulse width ($\pm 5\%$)	250 msec
Number of pulses	1 pulse per 30 sec, 30.27 sec inter burst (selectable)
Repetitions	Continually

Pulse Tone

Volume level	Adjustable (level 1~5)
Pitch ($\pm 5\%$)	158 to 662 Hz
Pulse width ($\pm 5\%$)	100 msec
Number of pulses	N/A
Repetitions	No repeat

Single Tone

Volume level	Adjustable (level 1~5)
Pitch ($\pm 5\%$)	Post Passing Tone: N/A Valid Tone: 440 Hz Invalid Tone: 168 Hz
Pulse width ($\pm 5\%$)	Post Passing Tone: 4000 msec Valid Tone: 70 msec Invalid Tone: 70 msec
Number of pulses	N/A
Repetitions	No repeat

Audio Alarm Reminder Tone

Volume level	Adjustable (level 1~5)
Pitch ($\pm 5\%$)	800 Hz
Pulse width ($\pm 5\%$)	200 msec
Number of pulses	N/A
Repetitions	Follow the interval setting

Specification *(cont.)*

Completion Sound

Volume level	Adjustable (level 1~5)	
Pitch ($\pm 5\%$)	NIBP	Temp
	1 st : 490 Hz 2 nd : 570 Hz 3 rd : 700 Hz	1 st : 700 Hz 2 nd : 570 Hz 3 rd : 490 Hz
Pulse width ($\pm 5\%$)	NIBP and Temp 1 st : 140 msec, 2 nd : 110 msec, 3 rd : 83 msec	
Number of pulses	NIBP and Temp 3 pulse per 0.36 sec	
Repetitions	No repeat	

Power Status Sound

Volume level	Adjustable (level 1~5)	
Pitch ($\pm 5\%$)	Battery	AC
	1 st : 1250 Hz 2 nd : 1150 Hz 3 rd : 1250 Hz	1 st : 1200 Hz 2 nd : 1100 Hz 3 rd : 1200 Hz
Pulse width ($\pm 5\%$)	Battery and AC 1 st : 76 msec, 2 nd : 56 msec, 3 rd : 44 msec	
Number of pulses	Battery and AC 3 pulse per 0.276 sec	
Repetitions	No repeat	

Volume Test Sound

Volume level	Not changeable
Pitch ($\pm 5\%$)	Alarm Volume Test: 540 Hz Pulse Tone Volume Test: 650 Hz Key Beep Volume Test: 440 Hz
Pulse width ($\pm 5\%$)	1000 ms
Number of pulses	N/A
Repetitions	No repeat

Measurement Parameters

NIBP

PR

PR Range	30 to 220 bpm						
PR Accuracy	±2% or ±3 bpm (whichever is greater)						
NIBP (Non-Invasive Blood Pressure)							
Technique	Oscillometric Measurement						
Measurement Modes	Spot check and Interval check						
NIBP AUTO Mode Intervals	Automatic NIBP measurements at intervals of Off, Cont, 1, 2, 2.5, 5, 10, 15, 30, 60 and 120 minutes						
Measurement Range	Adult <table style="margin-left: 20px;"> <tr> <td>SYS</td> <td>40 to 260 mmHg</td> </tr> <tr> <td>MAP</td> <td>26 to 220 mmHg</td> </tr> <tr> <td>DIA</td> <td>20 to 200 mmHg</td> </tr> </table>	SYS	40 to 260 mmHg	MAP	26 to 220 mmHg	DIA	20 to 200 mmHg
SYS	40 to 260 mmHg						
MAP	26 to 220 mmHg						
DIA	20 to 200 mmHg						
NIBP Accuracy	Mean error and standard deviation per ISO 81060-2:2013						
Pressure Display Range	0 to 300 mmHg						
Pressure Display Accuracy	Meets ISO 81060-2:2013						
Initial inflation pressure	Adult: Auto(default), 120, 140, 160, 180, 200, 220, 240, 260, 280 mmHg						
Automatic Cuff Deflation	Measurement time exceeding 180s in adult or maximum pressure value exceeding 300 mmHg in adult						
Overpressure Protector	330mmHg for Adult						
Defibrillator Protection	Protected						

SpO₂

PR

Range	<i>Nellcor SpO₂ module:</i> 20 to 300 bpm <i>MD1 SpO₂ module:</i> 300 to 300 bpm
Accuracy	<i>Nellcor SpO₂ module:</i> ±3 digits (at 20 ~ 250 bpm, Adult) ±3 digits (at 20 ~ 250 bpm, Low Perfusion) ±5 digits (at 20 ~ 250 bpm, Adult with Motion) <i>MD1 SpO₂ module:</i> ±2% or 2 bpm (whichever is greater)

SpO₂

Range	<i>Nellcor SpO₂ module:</i> 1 to 100 % <i>MD1 SpO₂ module:</i> 0 to 100 %
Accuracy	<i>Nellcor SpO₂ module:</i> ±2 digits (at 70 to 100 %) Low Saturation ±3 digits (at 60 to: 80 %) Low Perfusion ±2 digits (at 70 to 100 %) Adult with Motion ±3 digits (at 70 to 100 %) <i>MD1 SpO₂ module:</i> ±2 digits (at 70 to 100 %) (less than 70% is unspecified)

Specification *(cont.)*

Defibrillator Protection	Protected
Saturation accuracy will vary by sensor type as specified by the manufacturer.	
<i>Note: PR accuracy specification was proven by laboratory simulator tests, where oximeter was connected to the Oximetry simulator, set to the precise number of pulses per minute.</i>	
<i>Note: SpO₂ saturation accuracy - The monitor measurements are statistically distributed; about two-thirds of the monitor measurements can be expected to fall in this accuracy (ARMS) range. Reference the Clinical Studies section for test results. For a complete listing of SpO₂ accuracy across the full line of available Nellcor sensors, contact Medtronic, a local Medtronic representative, or locate it online at www.medtronic.com.</i>	
<i>Note: Specification applies to the monitor performance. Reading accuracy in the presence of low perfusion (detected IR pulse modulation amplitude 0.03% - 1.5%) was validated using signals supplied by a resident simulator. SpO₂ and PR values were varied across the monitoring range over a range of weak signal conditions and compared to the known true saturation and PR of the input signals.</i>	

Temperature

Temperature

Measurement Method	<i>Exergen, ACTT-1 and ACIT-1 thermometer: Infrared Filac 3000 thermometer: Thermistor</i>
Measurement Type	<i>Exergen, ACTT-1, and ACIT-1 thermometer: Spot check mode Filac thermometer: Spot check mode, Interval check mode</i>
Measurement Site	<i>Exergen thermometer: Temporal Filac 3000 thermometer: Oral, Axillary ACTT-1 thermometer: Ear ACIT-1 thermometer: Forehead</i>
Range	<i>Exergen thermometer 16.0°C to 43.0°C (60.8°F to 109°F) Filac 3000 thermometer 30.0°C to 43.0°C (86.0°F to 109°F) ACTT-1 and ACIT-1 thermometer 32.0°C to 43.0°C (89.6°F to 109°F)</i>
Probe Accuracy	<i>Exergen thermometer ±0.1°C (±0.2°F) Filac 3000 thermometer 35.5°C (95.9°F) to 42°C (107.6°F) ±0.1°C (±0.2°F) <i>Note: in fast predict mode, probe accuracy is ±0.3°C (±0.5°F) at 35.5°C (95.9°F) to 42°C (107.6°F)</i> ACTT-1 and ACIT-1 thermometer ±0.2°C (±0.4°F) for the range of 35.0°C to 42.0°C (95°F to 107.6°F) ±0.3°C (±0.5°F) for the range of <35.0°C (95°F) or 42.0°C (107.6°F)</i>
Defibrillator Protection	Protected

Internal Memory

Locally Saved Data	saves over 3,000 sets of data saves Resident ID and type, date and time saves alarm condition saves PR data from SpO ₂ and NIBP saves NIBP, SpO ₂ , Temp Measurements
Error Code	saves last 5,000 error codes detected by the monitor

Compliance

Item	Standard	Description
Classification	IEC 60601-1:2005+A1:2012 EN 60601-1:2006+A1:2013	Medical electrical equipment - Part 1: General requirements for basic safety and essential performance
Type of protection	IEC 60601-1:2005+A1:2012 EN 60601-1:2006+A1:2013	Type CF - Applied part (NIBP, SpO2, Temp: Filac 3000) Type BF - Applied part (Temp: Exergen, ACTT-1, ACIT-1)
Mode of operation	IEC 60601-1:2005+A1:2012 EN 60601-1:2006+A1:2013	Continuous
General	93/42/EEC as amended by 2007/47/EC	Directives for medical devices
	21CFR820	Code of federal regulations (for US)
	IEC 60601-1:2005+A1:2012 EN 60601-1:2006+A1:2013	Medical electrical equipment - Part 1: General requirements for basic safety and essential performance
	IEC 60529:1989+A1:1999 +A2:2013 EN 60529:1991+A1:2000 +A2:2013	Degrees of protection provided by enclosures (IPX2)
	ISO 14155:2011/Cor1:2011 EN ISO 14155:2011	Clinical investigation of medical devices for human subjects – part 1: General requirements
	AAMI HE75:2009/(R)2013	Human factors engineering guidelines and preferred practices for the design of medical devices
	IEC 60601-1-6:2010+A1:2013 EN 60601-1-6:2010	Medical electrical equipment - Part 1-6: General requirements for basic safety and essential performance - Collateral standard: Usability
	IEC 62366:2007+A1:2014 EN 62366:2008	Medical devices - Application of usability engineering to medical devices
	IEC 60601-2-49:2011 EN 60601-2-49:2001	Medical electrical equipment – Part 2-49: Particular requirements for the basic safety and essential performance of multifunction resident monitoring equipment
	ISO 10993-1:2009/Cor 1:2010 EN ISO 10993-1:2009 /AC:2010	Biological evaluation of medical devices – Part 1: Evaluation and testing
	ISO 10993-5:2009 EN ISO 10993-5:2009	Biological evaluation of medical devices – Part 5: Tests for in vitro cytotoxicity
	ISO 10993-10:2010 EN ISO 10993-10:2013	Biological evaluation of medical devices – Part 10: Tests for irritation and delayed-type hypersensitivity
	IEC 62304:2006+AC:2015 EN 62304:2006/AC:2008	Medical device software – Software life cycle processes

Specification *(cont.)*

Item	Standard	Description
	ISO 14971:2007 EN ISO 14971:2012	Medical devices - Application of risk management to medical devices
	2006/66/EC as amended by 2008/103/EC	Battery Directive
	93/86/EEC	Battery Disposal Directive
	2012/19/EU	Waste electrical and electronic equipment directive (WEEE)
	2011/65/EU	Restriction of Hazardous Substances (RoHS II)
	ISO 13485:2016 EN ISO 13485:2016	Quality systems - Medical Devices – Requirements for regulating purposes
Alarms	IEC 60601-1-8:2006+A1:2012 EN 60601-1-8:2007+A1:2013/AC:2014	Medical electrical equipment – Part 1-8: General requirements for basic safety and essential performance – Collateral standard: General requirements, tests and guidance for alarm systems in medical electrical equipment and medical electrical systems
Non-invasive blood pressure	EN 1060-3:1997+A2:2009	Non-Invasive Sphygmomanometers – Part 3: Supplementary requirements for electromechanical blood pressure measuring systems
	EN 1060-4:2004	Non-Invasive Sphygmomanometers – Test procedures to determine the overall system accuracy of automated non-invasive sphygmomanometers
	ISO 81060-2:2013	Non-invasive sphygmomanometers - Part 2: Clinical validation of automated measurement type
	IEC 80601-2-30:2018 EN 80601-2-30:2019	Particular requirements for the Safety, including essential performance, of Automatic Cycling Indirect Blood Pressure Monitoring Equipment
Oxygen saturation	ISO 80601-2-61:2011 EN ISO 80601-2-61:2011	Medical electrical equipment - Part 2-61: Particular requirements for basic safety and essential performance of pulse oximeter equipment
Temperature monitoring	ISO 80601-2-56:2009 ISO 80601-2-56:2017 EN ISO 80601-2-56:2012 EN ISO 80601-2-56:2017	Medical electrical equipment - Part 2-56: Particular requirements for basic safety and essential performance of clinical thermometers for body temperature measurement
	ASTM E1965:1998 (R2009) (for Spot check type temperature - infrared)	Standard Specification for Infrared Thermometers for Intermittent Determination of Resident Temperature

Item	Standard	Description
	EN12470-5:2000+A1:2009 (for Spot check type temperature - infrared)	Performance of infra-red ear thermometers (with maximum device)
Electromagnetic compatibility	IEC 60601-1-2:2014 EN 60601-1-2:2015	Medical electrical equipment – Part 1-2: General requirements for basic safety and essential performance – Collateral standard: Electromagnetic compatibility – Requirements and tests
	IEC 61000-3-2:2014 EN 61000-3-2:2014 EN 61000-3-2:2006+A1:2009+A2:2009	Harmonic Emission
	IEC 61000-3-3:2013 EN 61000-3-3:2013	Voltage Fluctuations/Flicker Emission
	IEC 61000-4-2:2008 EN 61000-4-2:2009	Electrostatic Discharge (ESD)
	IEC 61000-4-3:2006+A1:2008+A2:2010 EN 61000-4-3:2006+A1:2008+A2:2010	Radiated RF electromagnetic field
	IEC 61000-4-4:2012 EN 61000-4-4:2012	Electrical fast Transient/Burst (EFT)
	IEC 61000-4-5:2014 EN 61000-4-5:2014	Surge current
	IEC 61000-4-6:2013 EN 61000-4-6:2014	Conducted disturbances, induced by RF field
	IEC 61000-4-8:2009 EN 61000-4-8:2010	Power frequency (50/60Hz) Magnetic field
	IEC 61000-4-11:2004 EN 61000-4-11:2004	Voltage dips, short interruptions, and voltage variation on power supply input lines
	CISPR 11:2009+A1:2010 EN 55011:2009+A1:2010	Limits and methods of measurement of radio disturbance characteristics of industrial scientific and medical (ISM) radio-frequency equipment RF Emissions Group 1, Class B RF emissions
CISPR22:2008, EN 55022:2010	Information technology equipment – Radio disturbance characteristics - Limits and methods of measurement (For Test Method)	
Package	ISTA: Pre-Shipment Test Procedures (Procedure 2A, 2011)	Pre-Shipment Test Procedures (Package)
Reliability	IEC 60068-1:2013 EN 60068-1:2014	Environmental testing, Part1: General guidelines
	IEC 60068-2-27:2008 EN 60068-2-27:2009	Mechanical Drop Shock
	IEC 60068-2-6:2007 EN 60068-2-6:2008	Mechanical Sinusoidal Vibration

Specification *(cont.)*

Item	Standard	Description
	IEC 60068-2-64:2008 EN 60068-2-64:2008	Mechanical Random Vibration
	IEC 60068-2-1:2007 EN 60068-2-1:2007	Environmental testing - Part 2-1: Tests - Test A: Cold
	IEC 60068-2-2:2007 EN 60068-2-2:2007	Environmental testing - Part 2-2: Tests - Test B: Dry heat
	IEC 60068-2-30:2005 EN 60068-2-30:2005	Environmental testing - Part 2-30: Tests - Test Db: Damp heat, cyclic (12 h + 12 h cycle)
	IEC 60068-2-31:2008 EN60068-2-31:2008	Environmental testing: Rough handling shocks, primarily for equipment-type specimens
	MIL-STD-801G	ENVIRONMENTAL ENGINEERING CONSIDERATIONS AND LABORATORY TESTS
Labeling	EN1041:2008	Information supplied by the manufacturer with medical devices
	MDD	Information supplied by the Manufacturer with Medical devices - supportive
	FDA	Information supplied by the Manufacturer with Medical devices - supportive
Marking	IEC/TR 60878:2003	Graphical symbols for electrical equipment in medical practice
	ISO 15223-1:2016 EN ISO 15223-1:2012	Medical devices - Symbols to be used with medical device labels, labelling and information to be supplied - Part 1: General requirements
	ISO 15223-2:2010	Medical devices - Symbols to be used with medical device labels, labelling, and information to be supplied - Part 2: Symbol development, selection and validation
	ISO 7000:2014	Graphical symbols for use on equipment - Registered symbols
	EN 980:2008	Graphical symbols for use in the labeling of medical devices
	EN 50419:2006	Marking of electrical and electronic equipment in accordance with article II (2) of directive 2002/96/EC (WEEE)
Battery	UL 1642 (cells)	Lithium battery
	IEC 62133:2012	Secondary cells and batteries containing alkaline or other non-acid electrolytes & Safety requirements for portable sealed secondary cells, and for batteries made from them, for use in portable applications
	UN DOT 38.3	Lithium battery

Manufacturer's EMC Declaration

⚠ WARNING	For best product performance and measurement accuracy, use only accessories supplied or recommended by Direct Supply. Use accessories according to the manufacturer's directions for use and your facility's standards. The use of accessories, transducers, and cables other than those specified may result in increased emission and/or decreased immunity of the monitor.
⚠ WARNING	Portable RF communications equipment (including peripherals such as antenna cables and external antennas) should be used no closer than 30 cm (12 inches) to any part of the monitor, including cables specified by the manufacturer. Otherwise, degradation of the performance of this equipment could result.

The monitor is suitable for use in the specified electromagnetic environment. The customer and/or user of the monitor should assure that it is used in an electromagnetic environment as described below;

Electromagnetic Emissions (IEC60601-1-2)

Emission Test	Compliance	Electromagnetic Environment
RF emission CISPR 11	Group 1	The monitor must emit electromagnetic energy in order to perform its intended function. Nearby electronic equipment may be affected. The monitor is suitable for use in all establishments.
RF emissions CISPR 11	Class B	
Harmonic emissions IEC 61000-3-2	Class A	
Voltage fluctuations/flicker emission IEC 61000-3-3	Complies	

Specification *(cont.)*

Electromagnetic Immunity (IEC60601-1-2)

Immunity Test	IEC 60601-1-2 Test Level	Compliance Level	Electromagnetic Environment Guidance
Electrostatic discharge (ESD) IEC 61000-4-2	±8 kV contact ±2, 4, 8, 15 kV air	±2, 4, 6, 8 kV contact ±2, 4, 8, 15 kV air	Floor should be wood, concrete, or ceramic tile. If floors are covered with synthetic material, the relative humidity should be at least 30 %.
Electric fast transient/burst IEC 61000-4-4	±2 kV for power supply lines ±1 kV for input/output lines	±2 kV for power supply lines ±1 kV for input/output lines	Mains power quality should be that of a typical commercial and/or hospital environment
Surge IEC 61000-4-5	± 0.5, 1 kV differential mode ±0.5, 1, 2 kV common mode	± 0.5, 1 kV differential mode ±0.5, 1, 2 kV common mode	Mains power quality should be that of a typical commercial and/or hospital environment
Voltage dips, short interruptions and voltage variations on power supply	0 % UT for 0.5 cycle At 0°, 45°, 90°, 135°, 180°, 225°, 270° and 315°	0 % UT for 0.5 cycle At 0°, 45°, 90°, 135°, 180°, 225°, 270° and 315°	Mains power quality should be that of a typical commercial and/or hospital environment. If the user of the monitor requires continued operation during power mains interruption, it is recommended that the monitor be powered from an uninterruptible power supply or battery.
IEC 61000-4-11	0 % UT for 1 cycle At 0°	0 % UT for 1 cycle At 0°	
	70 % UT for 25/30 cycle At 0°	70 % UT for 25/30 cycle At 0°	
	0 % UT for 250/300 cycle At 0°	0 % UT for 250/300 cycle At 0°	
Power frequency (50/ 60 Hz) magnetic field IEC 61000-4-8	30 A/m	30 A/m	It may be necessary to position the monitor further from the sources of power frequency magnetic fields or to install magnetic shielding. The power frequency magnetic field should be measured in the intended installation location to assure that it is sufficiently low.

NOTE: UT is the AC mains voltage prior to application of the test level.

Electromagnetic Immunity (IEC60601-1-2)

Immunity Test	IEC 60601 test level	Compliance level	Electromagnetic environment guidance
The monitor is intended for use in the electromagnetic environment specified below. The customer or the user of the monitor should assure that it is used in such an environment.			
Conducted RF IEC 61000-4-6 Radiated RF IEC 61000-4-3	3 Vrms 150 kHz to 80 MHz	3 Vrms	Portable and mobile RF communications equipment should be used no closer to any part of the monitor including cables, than the recommended separation distance calculated from the equation appropriate to the frequency of the transmitter. Recommend separation distance $d = 1.2 \sqrt{p}$
	6 Vrms ISM bands (6.765 MHz to 6.795 MHz 13.553 MHz to 13.567 MHz 26.957 MHz to 27.283 MHz 40.66 MHz to 40.70 MHz)	6 Vrms	$d = 0.6 \sqrt{p}$
	3 V/m 80 MHz to 2.5 GHz (80 % AM at 2 Hz) According to IEC60601-1-2:2007	3 V/m	$d = 1.2 \sqrt{p}$ 80 MHz to 800 MHz $d = 2.3 \sqrt{p}$ 800 MHz to 2.7 GHz
	3 V/m 80 MHz to 2.7 GHz (80 % AM at 1 kHz) According to IEC60601-1-2:2014	3 V/m	$d = 1.2 \sqrt{p}$ 80 MHz to 800 MHz $d = 2.3 \sqrt{p}$ 800 MHz to 2.7 GHz
	20 V/m 80 MHz to 2.5 GHz (80 % AM at 1 kHz) According to particular standards	20 V/m	$d = 0.2 \sqrt{p}$ 80 MHz to 800 MHz $d = 0.4 \sqrt{p}$ 800 MHz to 2.7 GHz
			Where P is the maximum output power rating of the transmitter in watts (W) according to be transmitter manufacturer and d is the recommended separation distance in meters (m). Field strengths from fixed RF transmitters as determined by an electromagnetic site survey, ^a should be less than the compliance level in each frequency range. ^b Interference may occur in the vicinity of equipment marked with be following symbol: 

Specification *(cont.)*

Immunity Test	IEC 60601 test level	Compliance level	Electromagnetic environment guidance
<p>NOTE: At 80 MHz and 800 MHz, the higher frequency range applies. NOTE: These guidelines may not apply in all situations. Electromagnetic propagation is affected by absorption and reflection from structures, objects, and people.</p>			
<p>^a Field strengths from fixed transmitters, such as base stations for radio (cellular/cordless) telephones and land mobile radio, AM and FM radio broadcast, and TV broadcast cannot be predicted theoretically with accuracy. To assess the electromagnetic environment due to fixed RF transmitters, an electromagnetic site survey should be considered. If the measured field strength in the location in which the monitor is used exceeds the applicable RF compliance level above, the monitor should be observed to verify normal operation. If abnormal performance is observed, additional measures may be necessary, such as re-orienting or relocating the monitor.</p> <p>^b Over the frequency range 150 kHz to 80MHz, field strengths should be less than 3 V/m</p>			

Recommended Separation Distances

Recommended separation distance between portable and mobile RF communications equipment and the monitor

The monitor is intended for use in an electromagnetic environment in which radiated RF disturbances are controlled. The customer or the user of the monitor can help prevent electromagnetic interference by maintaining a minimum distance between portable and mobile RF communications equipment (transmitters) and the monitor as recommended below, according to the maximum output power of the communications equipment.

Rated Maximum Output Power of Transmitter in watt	Separation distance according to frequency of transmitter in meter			
	150 kHz to 80MHz $d = 1.2 \sqrt{p}$	150 kHz to 80MHz (ISM bands) $d = 0.6 \sqrt{p}$	80 MHz to 800MHz (Test level 20 V/m) $d = 0.2 \sqrt{p}$	800 MHz to 2.7GHz (Test level 20 V/m) $d = 0.4 \sqrt{p}$
0.01	0.12	0.06	0.02	0.04
0.1	0.38	0.19	0.06	0.13
1	1.2	0.6	0.2	0.4
10	3.8	1.9	0.63	1.3
100	12	6	2	4

For transmitters rated at a maximum output power not listed above, the recommended separation distance d in meters (m) can be estimated using the equation applicable to the frequency of the transmitter, where P is the maximum output power rating of the transmitter in watts (W) according to the transmitter manufacturer.

NOTE: At 80MHz and 800MHz, the separation distance for the higher frequency range applies

NOTE: These guidelines may not apply in all situations. Electromagnetic propagation is affected by absorption and reflection from structures, objects, and people.

Specification *(cont.)*

Immunity to proximity fields from RF wireless communications equipment (IEC 60601-1-2)

Test frequency (MHz)	Band ^a (MHz)	Service ^a	Modulation ^b	Maximum power (W)	Distance (m)	Immunity test level (V/m)
385	360 – 390	TETRA 400	Pulse modulation ^b 18 Hz	1.8	0.3	27
450	430 – 470	GMRS 460, FRS 460	FM ^c ± 5 kHz deviation 1 kHz sine	2	0.3	28
710 745 780	704 – 787	LTE Band 13, 17	Pulse modulation ^b 217 Hz	0.2	0.3	9
810 870 930	800 – 960	GSM 800/900, TETRA 800, iDEN 820, CDMA 850, LTE Band 5	Pulse modulation ^b 18 Hz	2	0.3	28
1720 1845 1970	1700 – 1990	GSM 1800; CDMA 1900; GSM 1900; DECT; LTE Band 1, 3, 4, 25; UMTS	Pulse modulation ^b 217 Hz	2	0.3	28
2450	2400 – 2570	Bluetooth, WLAN, 802.11 b/g/n, RFID 2450, LTE Band 7	Pulse modulation ^b 217 Hz	2	0.3	28
5240 5500 5785	5100 – 5800	WLAN 802.11 a/n	Pulse modulation ^b 217 Hz	0.2	0.3	9

NOTE If necessary to achieve the IMMUNITY TEST LEVEL, the distance between the transmitting antenna and the ME EQUIPMENT or ME SYSTEM may be reduced to 1 m. The 1 m test distance is permitted by IEC 61000-4-3.

^a For some services, only the uplink frequencies are included.

^b The carrier shall be modulated using a 50 % duty cycle square wave signal.

^c As an alternative to FM modulation, 50 % pulse modulation at 18 Hz may be used because while it does not represent actual modulation, it would be worst case.

Cables (IEC60601-1-2)

Cables and Sensors	Maximum Length	Complies with
AC Power Cable	2.5m	-RF emissions, CISPR 11, Class B/ Group 1 -Harmonic emissions, IEC 61000-3-2 -Voltage fluctuations/flicker emission, IEC 61000-3-3 -Electrostatic discharge (ESD), IEC 61000-4-2 -Electric fast transient/burst, IEC 61000-4-4 -Surge, IEC 61000-4-5 -Conducted RF, IEC 61000-4-6 -Radiated RF, IEC 61000-4-3
RJ-45 Cable	20m	
SpO ₂ Cable	4.0m	
NIBP Hose	1.2m	
Nurse call Cable	3.0m	
USB Type B Cable	1.5m	

Limited Warranty

We offer to you, as the original purchaser, a warranty for the Attendant® Touchscreen Vital Signs Monitor. Our warranty applies for the limited warranty period stated below. If any device or device part listed below is defective in material or workmanship during the applicable limited warranty period, we will repair or replace it at our cost. Please note that the decision to repair or replace a device or device part will be at our discretion. Our warranty applies only if the device is properly maintained by the original purchaser for normal, indoor use and does not cover normal wear and tear, modification of the device, or damage caused by abuse, improper use, failure to maintain, use which exceeds the published device limitations or the combination of any device with another product. In addition, our warranty does not cover fading, colorfastness, stains, spills or exposure to chemicals, odors, heat or light. In certain cases, we may provide you repair or adjustment instructions and/or replacement parts and ask you to perform a repair or adjustment or replace a defective part.

Our warranty gives you specific legal rights, and you may also have other rights, which vary from state to state. Please note that our limited warranty period begins when we ship the device to you. The limited warranty period and our obligations under the warranty end once you transfer the device to someone else, or at the end of the applicable limited warranty period identified below, whichever is earlier.

	Warranty (Parts)	Anticipated Usable Device Life
Attendant Touchscreen Vital Signs Monitor	2 years on device 6 months on accessories	2 years on device 6 months on accessories

Anticipated Usable Device Life is based on normal use with proper maintenance, cleaning and storage. You should still inspect, monitor and care for the device as described in this guide, as the device may need to be replaced sooner than anticipated in particular situations.

DIRECT SUPPLY MANUFACTURING, INC. MAKES NO IMPLIED WARRANTIES OF MERCHANTABILITY OR FITNESS FOR A PARTICULAR PURPOSE; THESE AND ALL OTHER IMPLIED WARRANTIES ARE SPECIFICALLY DISCLAIMED. TO THE FULLEST EXTENT ALLOWED BY LAW, DIRECT SUPPLY MANUFACTURING, INC. WILL NOT BE LIABLE FOR ANY INCIDENTAL, SPECIAL, CONSEQUENTIAL OR PUNITIVE DAMAGES, OR LOST PROFITS THAT MAY RESULT FROM THE DEVICE OR YOUR USE OR INABILITY TO USE THE DEVICE EVEN IF ADVISED OF THE POSSIBILITY OF SUCH DAMAGES. OUR TOTAL LIABILITY TO YOU, IF ANY, IS LIMITED TO THE PRICE OF THE PRODUCT OR SERVICE GIVING RISE TO YOUR CLAIM. Some states do not allow an exclusion or limitation of incidental or consequential damages, or how long an implied warranty lasts, so the above limitations or exclusions may not apply to you. If implied warranties are not excluded, and to the extent allowed by law, we limit any and all implied warranties to the applicable warranty period identified above. Except for rights under any applicable state law, the remedies provided under this warranty are your sole and exclusive remedy for any breach of our warranty and state the entire limit of our responsibilities.

Customer Service

Our promise to you is that you will have a convenient and easy ordering experience, receive a quality Attendant Connected Vital Signs Monitor, and enjoy outrageous customer service. If you have any questions about the Attendant Connected Vital Signs Monitor you have purchased or would like to request warranty service, please contact **Direct Supply Equipment & Furnishings** at 1-800-634-7328, 6767 W Champions Way, Milwaukee, WI 53223, SalesSupport@DirectSupply.com.



DirectSupply.com

APTURA / EQUIPMENT & FURNISHINGS / DSSI / TELS

Distributed by Direct Supply Manufacturing, Inc. 6635 W Champions Way, Milwaukee WI 53223.

© 2021 Direct Supply Manufacturing, Inc. All Rights Reserved. Direct Supply®, Attendant®, and all associated logos are the registered trademarks of Direct Supply Inc., used under license